



Hydraulic Pumps & Motors Vane Troubleshooting Guide

Denison Vane Technology

aerospace
climate control
electromechanical
filtration
fluid & gas handling
hydraulics
pneumatics
process control
sealing & shielding



ENGINEERING YOUR SUCCESS.

Table of contents

1. INTRODUCTION	4
1.1. PRESENTATION	4
1.2. HOW TO USE THIS GUIDE	4
1.3. WHY A PARKER VANE PUMP SHOULD NOT BREAK DOWN	5
1.4. BASIC PRECAUTIONS FOR A LONG LIFETIME	7
2. ANALYSIS OF THE FAILURES	8
2.1. MECHANICAL FAILURES	8
1. Problems on shafts	8
2. Bad shaft/coupling connection	10
3. Dowel pin of the cartridge not correctly positioned in the housing	11
4. Cartridge screws not properly mounted	12
5. Hollow push pin wrongly mounted	12
6. Loose fasteners	12
7. Marks on port plates	12
2.2. THE CONSEQUENCES OF MECHANICAL FAILURES	13
1. Fretting corrosion	13
2. Shaft splines/keyed shaft worn out on their total length	13
3. Shaft splines/keyed shaft worn out on a part of their length	13
4. Fatigue shaft rupture	14
5. Bush/bearing problems	16
6. Marked cam ring	16
7. Shaft seal losing contact	17
8. Dissymmetrical wear on the port plates	17
9. Broken dowel pin	17
10. Noisy pump	17
11. Broken screws	18
12. Parallel marks on the port plate	18
2.3. PRESSURE FAILURES	19
1. Pressure overshoot	19
2. Instant pressure overshoot	19
3. The consequences of instant pressure overshoot	19
4. Cycled overpressurization	21
5. The consequences of cycled overpressurization	22
6. Pressure gradients	24
7. Consequences of too high pressure gradients	24
2.4. PHYSICAL, CHEMICAL OR HYDRAULIC FAILURES	25
1. Start-up without a proper air bleed-off	25
2. Air contamination - Fluid foaming	25
3. Solid particle contamination	32
4. Consequences of solid particle contamination	33
5. Water contamination	36
6. Consequences of water contamination	37
7. Viscosity failures	38
8. Consequences of viscosity failures	39
9. Unsuitable fluids	40
10. Unsuitable grease	41

Table of contents

3. SPECIFICS OF VANE MOTORS FAILURES AND CAUSES	42
3.1. TORQUE OVER THE CATALOGUE LIMITS	43
3.2. BAD AIR BLEED-OFF OR AIR INTAKE	43
3.3. TOO HIGH PRESSURE IN A OR B LINE	44
3.4. TOO HIGH PRESSURE IN THE DRAIN LINE	44
3.5. EXCESS OF AIR IN THE FLUID	45
3.6. CAVITATION	45
3.7. POLLUTION	46
3.8. TOO LOW VISCOSITY	47
4. TROUBLESHOOTING CHARTS	48
4.1. TROUBLESHOOTING TABLE FOR VANE PUMPS	50
1. No flow, no pressure	50
2. Flow below rated	50
3. No pressure	51
4. Not enough pressure	52
5. Unusual noise level	52
6. Unusual heat level	52
7. Shaft seal leakage	53
4.2. TROUBLESHOOTING TABLE FOR VANE MOTORS - M3* / M4* SERIES	54
1. No rotation	54
2. Stalls easily	54
3. Not enough speed	54
4. Erratic speed	54
5. Unusual noise level	55
6. Unusual heat level	55
7. Shaft end leakage	55
4.3. TROUBLESHOOTING TABLE FOR VANE MOTORS - M5* SERIES	56
1. No rotation	56
2. Stalls easily	56
3. Not enough speed	56
4. Erratic speed	56
5. Unusual noise level	57
6. Unusual heat level	57
7. Shaft end leakage	57
5. GENERAL INFORMATION	61
6. COMPONENT ANALYSIS TABLE	Folded last page

1. INTRODUCTION

1.1. PRESENTATION

The main purpose of this guide is to help all the Parker vane product users to understand the most common causes of destruction of these hydraulic vane pumps and motors in service. Experience has shown us that failures occurring in the first 500 hours of service are real premature failures. Failing to follow instructions, or ignoring the correct application and functioning limits of the units, inevitably leads to premature failures. It is also very important to point out that 80 % of the failures are linked to fluid contamination incidents.

This Vane Troubleshooting Guide comes as an addition to our sales and maintenance documentation available at www.parker.com/vanepump.

1.2. HOW TO USE THIS GUIDE

Just like for any book, we recommend you to read this Vane Troubleshooting Guide from the beginning to the end. However, you may wish to find answers in another way, then the table of contents and the below comments are for you.

- **Interpret the physical damages on a stripped vane pump or vane motor**

The component analysis table on the last page indicates all the pictures of the failed components. Go to the corresponding pages to recognize the failed component and to understand the cause of the failure.

- **The most common failure causes**

The chapter 2 is detailing the major incidents you may encounter on the vane pumps (cavitation, aeration, misalignment...) and their consequences.

The chapter 3 is covering the same topic but for the vane motors.

- **Fault finding while the pump or motor is running**

If you are facing problems in working conditions, the troubleshooting tables for vane pumps and vane motors in the chapter 4 will help you to find out what can be wrong and the eventual remedies (Failure-Cause-Solution).

1.3. WHY A PARKER VANE PUMP SHOULD NOT BREAK DOWN

Unlike most other hydraulic technologies, the Parker vane pump design is hydraulically balanced. One cannot estimate the lifetime expectancy of these pumps by simply calculating the lifetime of the ball bearing as no internal load, neither axial nor radial, is applied on the shaft. The main purpose of the ball bearing in the Parker vane pump is to absorb eventual external shaft misalignments or abnormal coupling loads.

As shown on the drawing hereafter, the two symmetrical high pressure zones have a self centering effect on the rotating components. This is a hydrostatically balanced pump, both axially and radially.

Each single vane is independently loaded in order to always be kept against the cam ring contour. The specific push pin design reduces the possible internal leakage, reduces the possible vane/cam ring wear (also thanks to the precise balancing of the forces under and over the vane), considerably lowers the noise level, allows higher pressure capabilities, extends the lifetime...

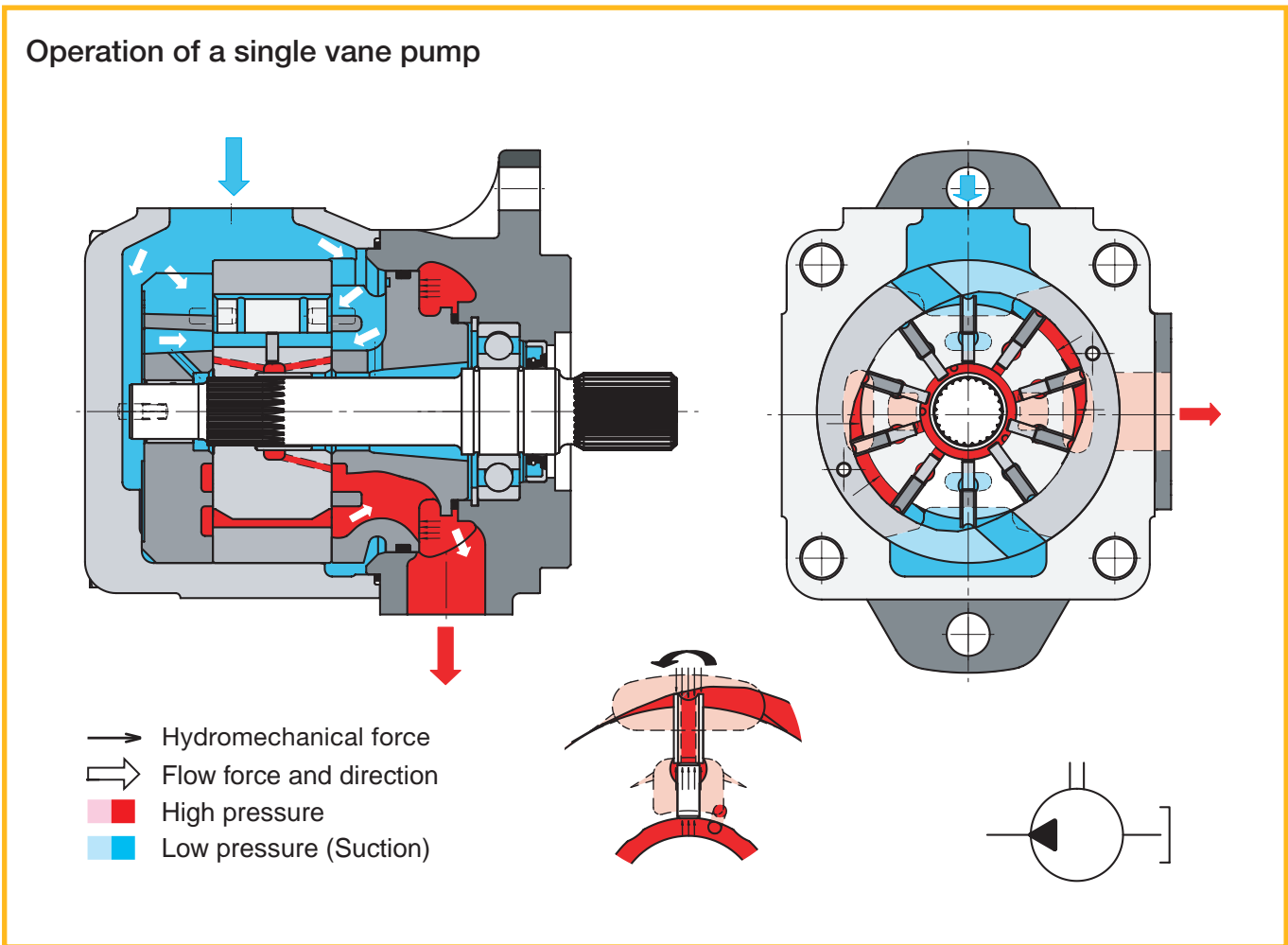

Why a Parker vane pump should not break down Denison Vane Pumps & Motors

In addition to this push pin design there is the double lip technology of the vane. This vane technology, combined with the push pin design, is contributing to bring the unique overall performances of the Parker Vane pumps. The double lip design allows the pressure all around the vane to be the same, whether it is on its top, bottom or sides. This is made possible thanks to the double lip shape and the balancing through the holes in the vanes. Here again, the components are hydrostatically balanced. Another advantage of the double lip design is the fact that one lip seals the low pressure area when the other one seals the high pressure area. This increases the lifetime of the pump, especially when working with contaminated fluid. The wear, due to the particles of pollution, will have a negative effect but mainly on the first lip, when the second one, working in the high pressure area, will keep its original sealing, maintaining a high volumetric efficiency. This double lip technology helps to compensate the wear, and the effect of contamination on the Parker vane design is not a major issue of pump failure as it may be with pumps of other technologies.

Every port plate and cam ring gets a surface treatment to increase its life expectancy.

On each cam ring, for example, a dry lubricant coating is applied to the cam profile. This coating will assure a good start-up, even in bad priming conditions, minimizing the risk of micro-seizures. With the dry lubricant coating, the deficiency of fluid is compensated but not replaced. This is done for short time deficiencies.

Our experience taught us that, outside pressure and mechanical failures, the most common breakdowns are linked to the quality of the fluid and a lack of lubrication. As soon as there is a rupture of the lubricating film, the failure is imminent. Here are some examples of very common causes:

- Air in the fluid (cavitation, aeration),
- Large size solid particles,
- Chemical agents (water, wrong additives, tar...),
- Too high or too low viscosity,
- Overheating (shaft alignment),
- Flow of the system coming back to the pump,
- Poor fluid quality losing its main chemical characteristics.
- ...

Thus, good filtration and fluid quality, good thermal stability, when combined with a well designed hydraulic system and a correct knowledge of hydraulics, will always increase the lifetime of the hydraulic components.

Our vane pump technology is a heavy duty engineering design that will last years when elementary precautions are taken.

1.4. BASIC PRECAUTIONS FOR A LONG LIFETIME

The Parker vane products are designed for a long life, and the following minor precautions should help you to avoid premature breakdowns :

- Do not forget to have a correct air bleed-off at start-up.
- Always check the fluid velocity (inlet & outlet), which should determine the correct sizes of pipes, hoses and connectors. The fluid velocity for the inlet line must be limited to 1.9 m/s, and 6.0 m/s for the discharge line.
- No strainer on the inlet line is recommended (If absolutely necessary, it should be 250 microns minimum and its pressure drop at high fluid viscosity has to be checked). A high quality return line filter is preferred.
- Always pay attention to the viscosity of the oil versus its temperature. Even a small change in the temperature can have a big effect on the viscosity, hence the lubrication of the parts.
- Measure the pressure at the inlet port. The position of the tank and the shaft rotational speed are influencing this parameter. Please refer to the minimum inlet pressure tables in our catalogues.
- Consider the ratio flow/tank capacity and the cooling requirements of the power unit.
- Proper coupling with the driving source and good shaft alignments can be classic "forgotten things", as well as the lubrication of these links.
- Be sure the fluid selection versus the application conditions is appropriate. Viscosity index, viscosity grade (ISO 32, 46, 68...), environment (biodegradability, fire resistance, normal conditions), operating temperature range, filterability, deaeration capability and thermal stability, are all to be considered.
- When a pump is used on a very fast pressure cycling machine, attention should be paid to the relationship between the pressure rise/fall gradient and the inlet pressure, in order to avoid cavitation. We recommend maximum limits, with mineral oil, of 5000 bar/s (72500 PSI/s) for pressure rise and 6000 bar/s (87000 PSI/s) for pressure fall.

Exploded view of a double vane pump

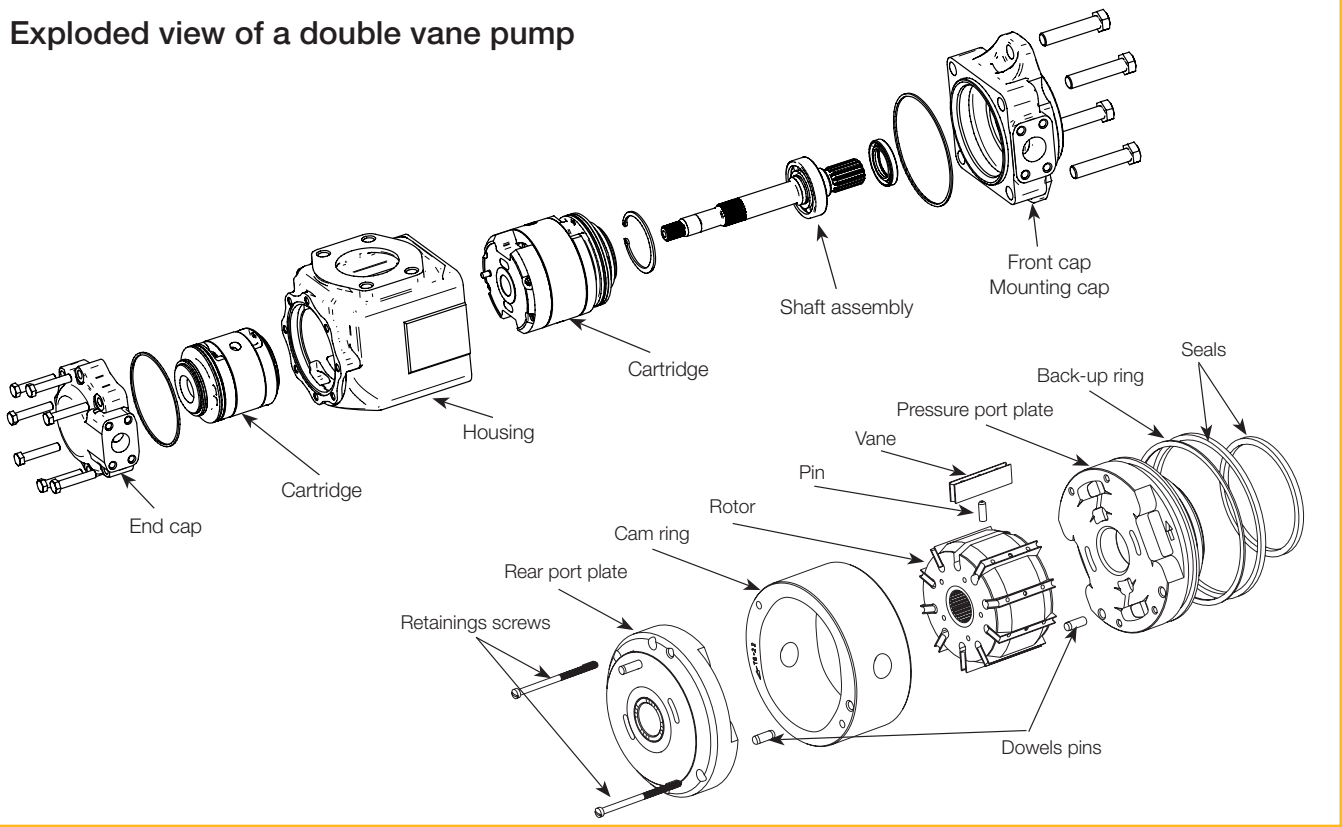

2. ANALYSIS OF THE FAILURES

The systematic analysis of the failures allows the causes to be determined with logic. These failures may be either distortion, shearing, surface seizure or scoring.

If the failure is shearing, we can almost certainly say it is the consequence of a brutal or a fatigue failure. A brutal failure is due to sudden increase in loads, exceeding the material strength limit or its resistance to shocks. A fatigue failure is the result of reaching the tensile limit of the sensitive point of a component. Studying the crystalline faces will allow us to determine the mechanical causes that provoked the failure.

This vane troubleshooting guide has been prepared in such a way that it allows everyone to quickly reach a satisfactory conclusion.

2.1. MECHANICAL FAILURES

Mechanical failures are due to external physical parameters that change the mechanical structure of the materials. The causes of these incidents are mostly axial and radial shaft overloads, rotary bending (flexion) and torsion (twisted) fatigue failures.

1. Problems on shafts

Bad alignment, wrong mechanical link (bracket, chassis deformation, bad bell housing, too loose damping elements...) can create :

Misalignment.

Out of squareness.

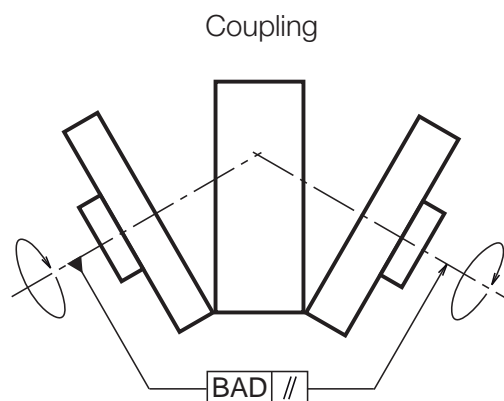
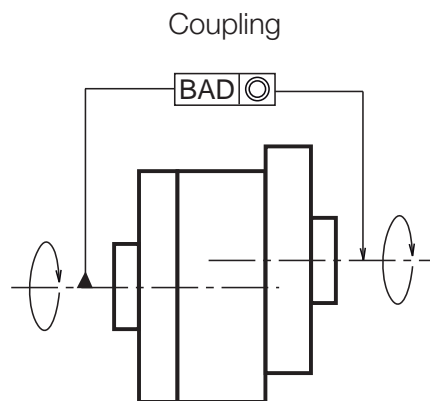

Consequence pages

- Fretting P 13
- Shaft rupture P 14 & 15
- Rear bushing P 16
- Marked cam ring P 16
- Shaft seal problem P 17
- Dissymmetrical wear on the port plates P 17
- Ball bearing worn or destroyed

- Fretting P 13
- Shaft rupture P 14 & 15
- Rear bushing P 16
- Marked cam ring P 16
- Shaft seal problem P 17
- Dissymmetrical wear on the port plates P 17
- Ball bearing worn or destroyed

- Gap between the two coupling flanges is too small (axial loads / radial loads). See coupling manufacturer's convenient clearance required depending on the torque.

- Coupling is unbalanced = radial load.

- Too high load on a belt driven system (belt drives are not recommended).

- Non-homokinetic transmission due to unbalanced cardan shaft (or universal joint) meaning inconstant shaft speed.

- Too high moment of inertia due to heavy couplings (like chain couplings) or couplings with very large diameter.

Coupling

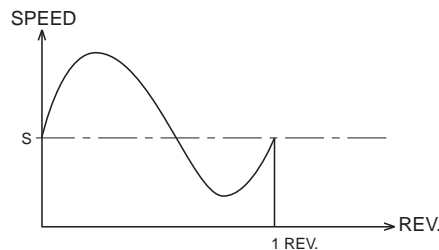
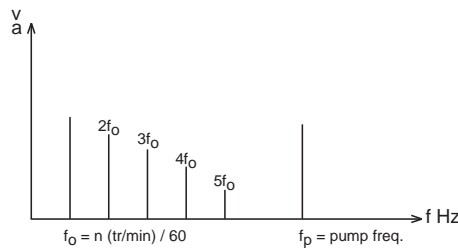
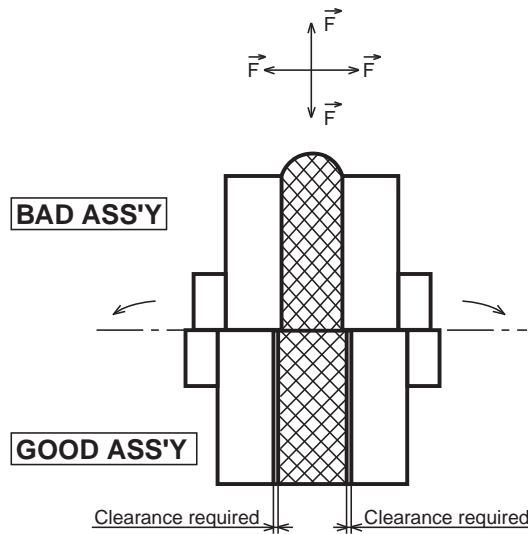

Consequence pages

- Fretting corrosion P 12
- Shaft rupture P 14 & 15
- Ball bearing worn out
- Rear bushing P 16

- Shaft rupture P 14 & 15
- Bushing P 16
- Marked cam ring P 16
- Shaft seal problem P 17
- Dissymmetrical wear on the port plates P 17

- Shaft rupture P 14 & 15
- Bushing P 16
- Marked cam ring P 16
- Shaft seal problem P 17

- Bracket deformation when the pump is loaded.

- Hose strain force (reaction to a brutal pressure compression / decompression)

- Rigid pipe mounting strain.

- Input torque over the limit (too high pressure versus displacement for the capacity of the chosen shaft).

2. Bad shaft / coupling connection

- "Locking screw" not properly positioned on the key (keyed shaft).

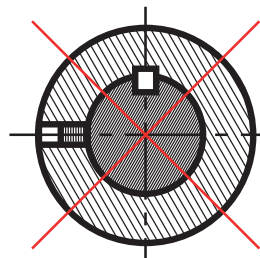
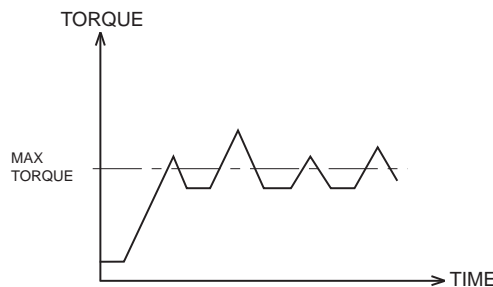
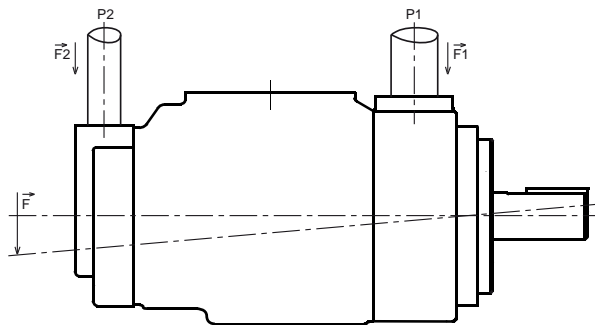
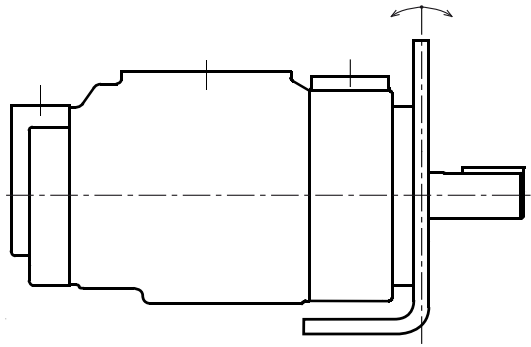

Consequence pages

- Shaft rupture P 14 & 15
- Bushing problems P 16
- Marked cam ring P 16
- Seal problems P 17
- Wear on port plate P 17

- Shaft rupture P 14 & 15
- Bushing problems P 16
- Marked cam ring P 16
- Seal problems P 17
- Wear on port plate P 17

- Shaft rupture (torsional fatigue) P 14 & 15
- Shaft wear P 13

- Shaft rupture P 14 & 15
- Rear bushing P 16

- Wrong machining of the couplings.

- Incorrect tolerance fit between the shaft diameter and the coupling diameter.

- Key way in the coupling not properly centered with the main bore axis.

- Bad heat treatment (too high or too low).

- Shaft not properly engaged (too small surface of spline or key used).

- Bad (or no) lubrication of splined shafts / coupling.

3. Dowel pin of the cartridge not correctly positioned in the housing

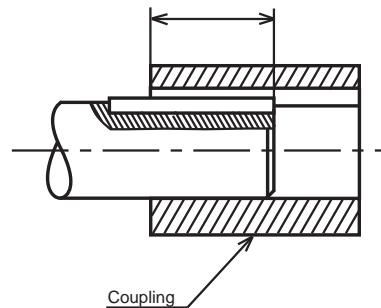
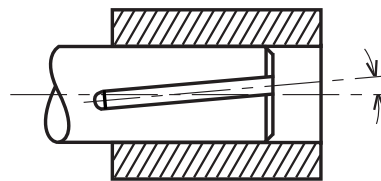
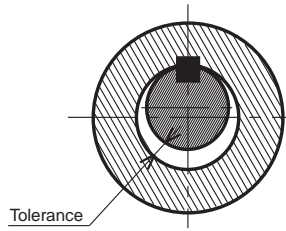

Parker requires a grease with disulfide of molybdenum base for the lubrication of the shafts.

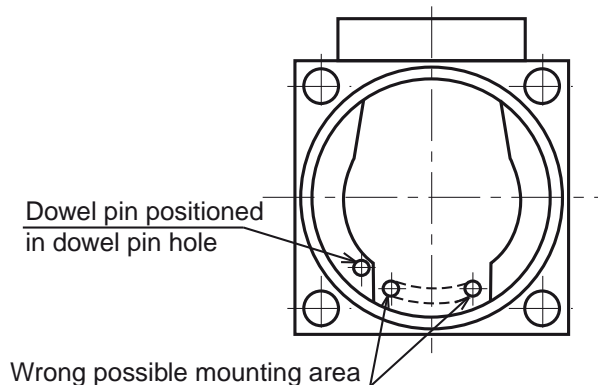

Consequence pages

- Fretting P 13
- Shaft rupture P 14 & 15
- Shaft worn out P 13

- Shaft rupture P 14 & 15

- Wear of the splines P 13
- Wear of the key P 13

- Spline wear P 13

- Dowel pin rupture P 17
- No pressure
- Unconstant flow
- Cavitation
- Noisy pump

4. Cartridge screws not properly mounted

After a cartridge modification, no precaution has been taken to check if the rotor could freely rotate in the newly built cartridge. Some vanes can have tilted and therefore be squeezed between the port plates. These screws should be lightly tightened as they just hold the parts together to obtain a cartridge. After reassembling a cartridge, always check if the rotor & vanes can freely rotate in the cartridge.

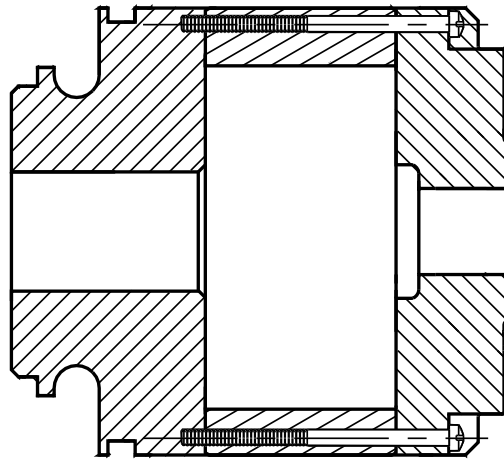

5. Hollow push pin wrongly mounted

Pin installed upside down in the T6*M mobile cartridges.

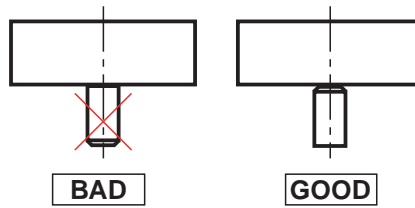

6. Loose fasteners

(ex. : after modifying the pump, the assembling screws were not tightened at the proper torque and worked loose).

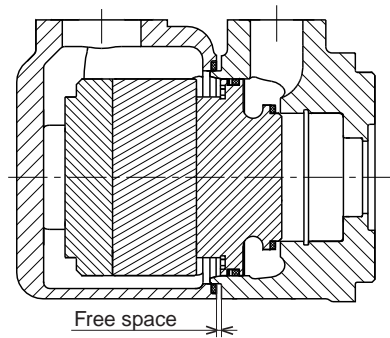

7. Marks on port plates

that disturb the cycle of the pump. Even a small scratch between the inlet & the pressure area can destabilize the vanes.

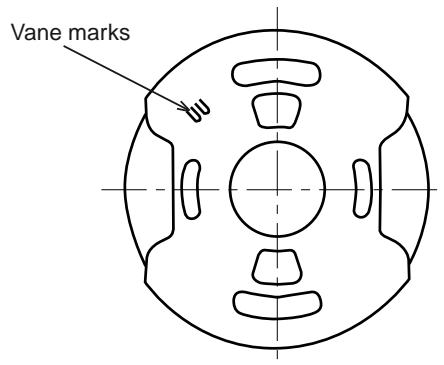

Consequence pages

- Vane marks P 12
- Vane marks P 18

- Noisy pump
- Unstable flow

- Broken screws P 18

- Vane marks P 18
- Noisy pump
- Limited pressure
- Unconstant flow

2.2. THE CONSEQUENCES OF MECHANICAL FAILURES

1. Fretting corrosion

This phenomenon appears when the solicitations are great and when there is a slight vibration movement. These movements will "create" metallic oxides. Being very abrasive, they will weaken the structure of the component and will favour the start of the fatigue rupture (twisted).



Incident pages

- Bad shaft / coupling link P 10
- Bad coupling manufacturing P 11
- Bad grease when assembling

2. Shaft splines / keyed shaft worn out on their total length



- Bad shaft / coupling connection P 11
- Bad lubricant (Grease)
- Over torque values P 10
- Highly cycled

3. Shaft splines / keyed shaft worn out on a part of their length



- Over torque values P 10
- Too small splined or key surface being used P 11

The consequences of mechanical failures

4. Fatigue shaft rupture

- Perpendicular, centered, rotational bending fatigue rupture.



Rotational bending fatigue

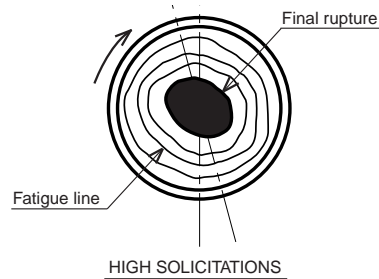

- Perpendicular, over-centered rotational bending fatigue rupture.



Rotational bending fatigue

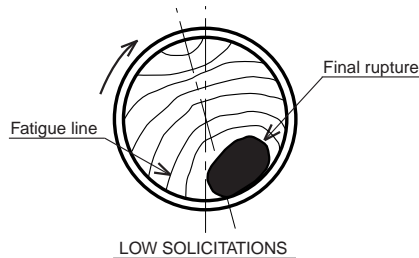

Incident pages

- Bad alignment P 8
- Out of squareness P 8
- Unbalanced coupling P 9
- Too high radial load P 9
- Non homokinetic P 9
- Too great moment of inertia P 9
- Bracket chassis deformation P 10
- Hose strain force P 10
- Bad shaft / coupling link P 10

- Bad alignment P 8
- Out of squareness P 8
- Unbalanced coupling P 9
- Too high radial load P 9
- Non homokinetic drive P 9
- Too great moment of inertia P 9
- Bracket chassis deformation P 10
- Hose strain force P 10
- Bad shaft / coupling link P 10

The consequences of mechanical failures

- Twisted torsional rupture.



Torsional fatigue

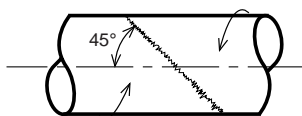

- Perpendicular, torsional fatigue rupture.

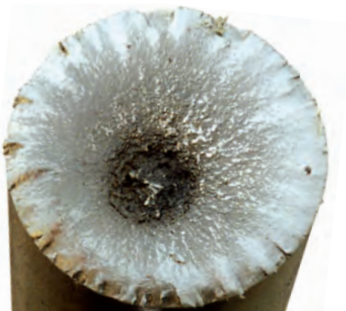

Torsional fatigue

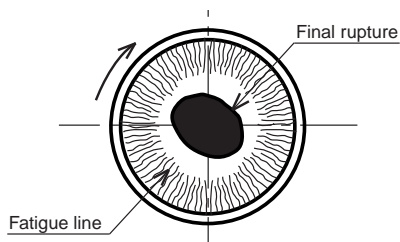

Incident pages

- Fretting corrosion P 13
- Over torque limits P 10

- Torsional fatigue with peak torque values P10

The consequences of mechanical failures

5. Bush / bearing problems

- Front or rear bearing or bush with heavy wear.

- Bush "welded" on the shaft.

- Rear bush moving out of the rear port plate.

- Front ball bearing = inner ring damaged

6. Marked cam ring

- Marks made by the rotor on the smallest diameter. If the contact between the rotor and the cam ring is important, it will transform the hardness of the cam ring and create local tensions (cracks).

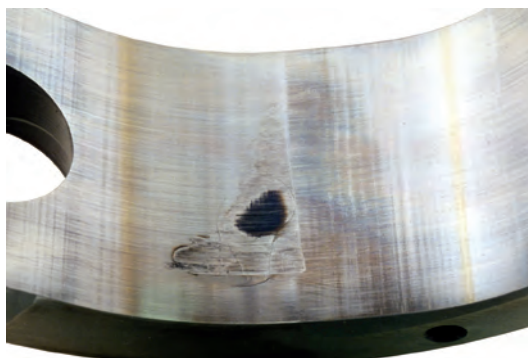
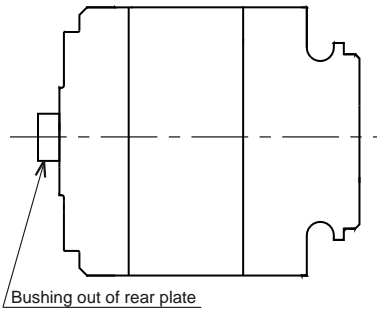

Incident pages

- Problems on shafts P 8, 9 & 10
- Bad shaft / coupling connection P 11

- Problems on shafts P 8, 9 & 10
- Bad shaft / coupling connection P 11

- Problems on shafts P 8, 9 & 10
- Bad shaft / coupling connection P 11

- Problems on shafts P 8, 9 & 10

- Problems on shafts P 8, 9 & 10
- Bad shaft / coupling connection P 11

7. Shaft seal loosing contact

- Air intake
- Leakage

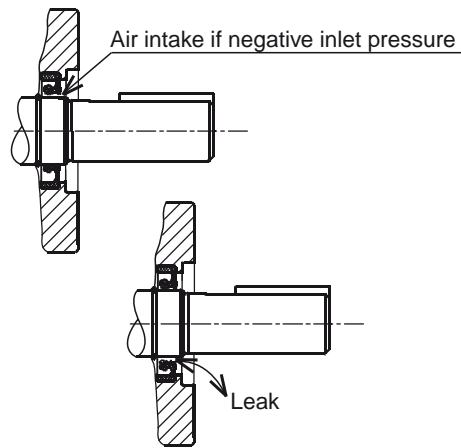

Incident pages

- Problems on shafts P 8, 9 & 10
- Bad shaft / coupling connection P 11

- Problems on shafts P 8, 9 & 10
- Bad shaft / coupling connection P 11

8. Dissymmetrical wear on the port plates



- Problems on shafts P 8, 9 & 10
- Bad shaft / coupling connection P 11

9. Broken dowel pin

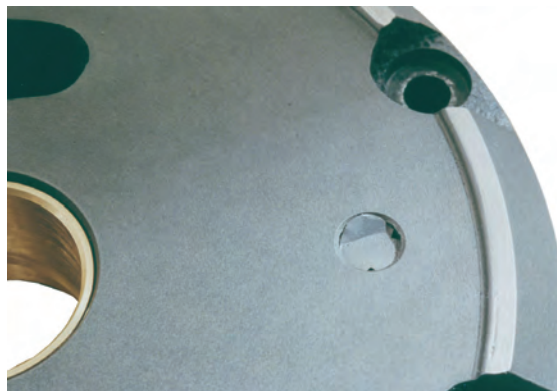

- Over torque limits P 10
- Cartridge not properly mounted in the housing P 11

10. Noisy pump



- Hollow pin vane P 12

11. Broken screws

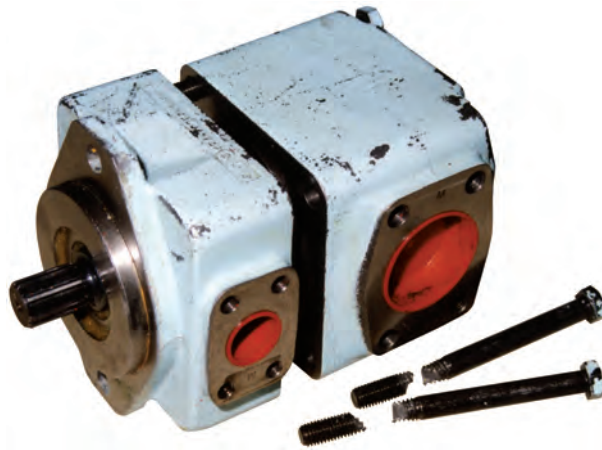

Incident pages

- Loose pump fasteners P 12

12. Parallel marks on the port plate

- Tilted vanes marked the port plate but the pump did not rotate.

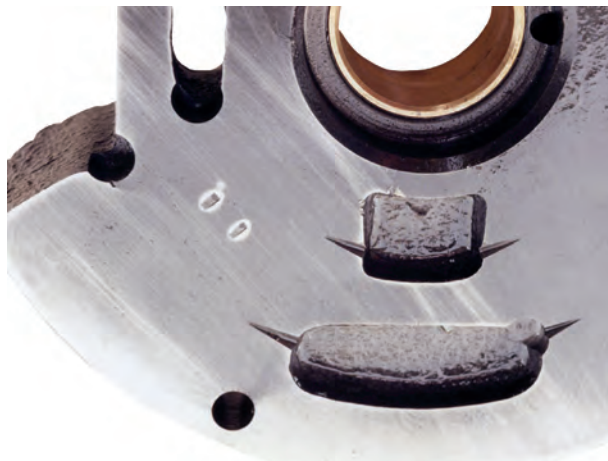

- Cartridge not properly assembled P 12

- Tilted vanes but the pump did rotate. The result is scars on the port plate.



- Cartridge not properly assembled P 12

2.3 PRESSURE FAILURES : OVERTHOOT & PRESSURE GRADIENTS

1. Pressure overshoot

The working pressures in hydraulic systems are constantly rising and the pressure overshoots are doing the same. The effects on the hydraulic pumps, whichever technology is used, are always bad. We split-up this phenomenon into two different categories : "Instant pressure overshoot" and "Cycled overpressurization".

The final consequences of these two problems are the same : the failure of components. However they are damaged differently if it is an "Instant pressure overshoot" or a "Cycled overpressurization". The peak can come from a valve that makes the pressure relief valve open, or from the system. Valves, piping rigidity and distance to the pumps have a great impact on these pressure peaks. The fact is that the pressure rises over the initial settings or designed settings. The pump can be protected by a check valve, or not. When a check-valve closes itself too slowly, the flow comes backwards into the pump. This problem will be seen in the "cycled overpressurization". These pressure peaks can reach 2 to 5 times the adjusted maximum pressure valve. They are not readable with a standard manometer, and only recordings with electronic sensors will show the facts.

2. Instant pressure overshoot

This is a brutal high peak of pressure. The consequence is that the mechanical strength of the material is exceeded.

This will cause some brutal failures of components such as the port plates (on the high pressure distribution area), the rotor (split), the cam ring (cracked), the shaft (broken), the dowel pin (cut in two parts).

3. The consequences of instant pressure overshoot

- Cracks or rupture of the pressure port plate.



- Cracks or rupture of the rotor.



- Cam ring cracked.



- Shaft broken, with a perpendicular "clean cut".



- Dowel pin cut in two parts.



4. Cycled overpressurization

- The pressure rating of the system is just over the allowed pressure specified.

This will give a fatigue failure on the long term. It is the sum of the pressure exceeding limits that will weaken the mechanical strength of the components. Such specific failures can be seen on the following components : cam ring, vanes, shaft, side plates, rotor splines or the rotor rupture between two vane slots.

Another effect is the deflection of the cam rings' external diameter due to this overpressure. The consequence of this expansion is to reduce the space between the rotor OD and the minor diameter of the cam ring. When this gap is too narrow, the rotor may come in contact with the cam ring. If both cam deflection and shaft misalignment happen at the same time, then the contact often arises.

Another distortion effect is this overpressure pushing on the pressure port plate. The deflection of the pressure port plate will, in its center, reduce the normal clearance between the port plates and the rotor. The film of oil lubricating these components will be reduced, its temperature will rise because of the narrow gap, and a friction welding will result. The total seizure will then be the consequence if the local temperature rises too high.

- The system is not secured with a check valve or this check valve is too slow to open.

During the opening time of the "slow" pressure relief valve, the flow delivered from actuators or the pump has to go somewhere. Usually, the relief valve opens and this flow goes back to the tank.

Here, not being able to go back to the tank, the flow will go back to the pump. If the check valve closes fast enough, the pressure will increase and accelerate the relief valve opening to allow the flow back to the tank. If there is no check valve or if it is too slow, the flow will return to the pump. This flow will then push the rotor forwards, which will wear the rotors' splines. The gap between the rotor & the port plates will then be increased and create a local cavitation. This local cavitation will suck the oil lubricating the sides. Without enough oil, the local overheat will start a pump seizing. The vanes will have marks on both sides, the splines of the shaft and the rotor will be worn (on both splined teeth flanks).

5. The consequences of cycled overpressurization

- Vanes.

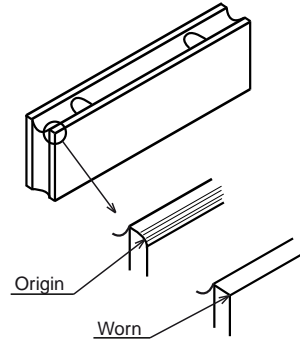

- Cam ring rupture / cracks.



- Rotor / cam ring contact at the "smallest diameter" level.

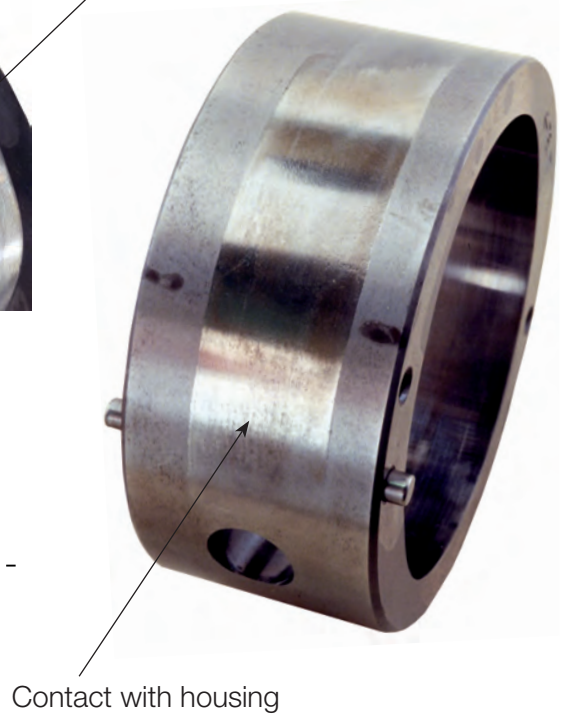
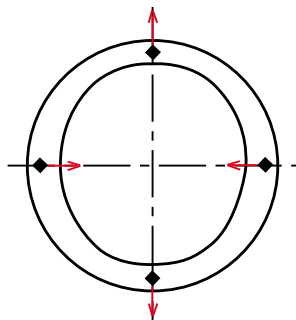
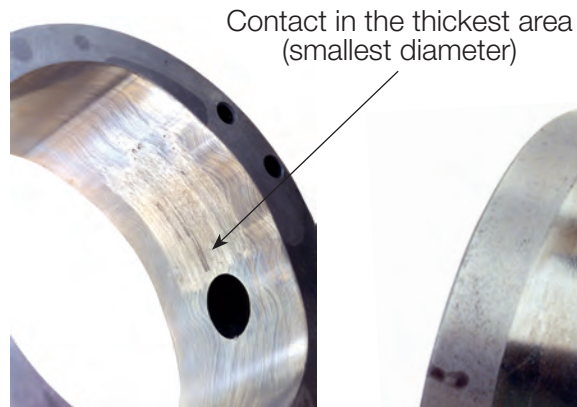

- Shaft having its internal splines worn out.



- Shaft rupture :
• Torsional fatigue ruptures
Perpendicular : few cycles but very high torque.



• Twisted shaft, often under high cycling.



• Twisted shaft.

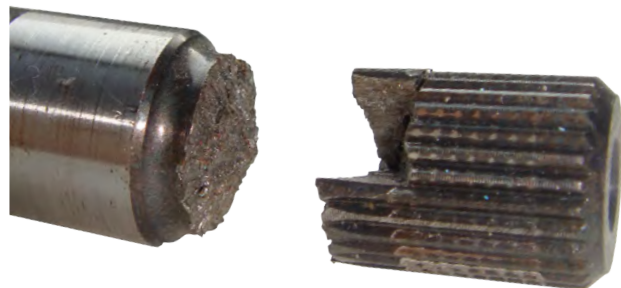

- Port plates deformations = contact on the smallest diameter of the rotor.

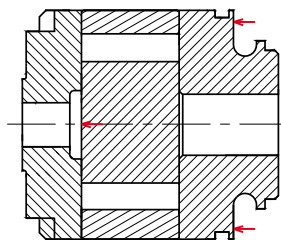

6. Pressure gradients

This pressure increase or decrease, in bar per second (bar/s), is known by most people but often forgotten in many hydraulic systems. The velocity of this increase/decrease is very important. Beyond the fact that it stresses the materials, it has some big effects on the velocity of the fluid. These sudden pressure changes modify the internal leakage of the pumps. Depending on the pumps' technology, these allowable pressure gradients are more or less important. The Denison vane technology of Parker can be used safely up to 5000 bar/s for pressure rise and 6000 bar/s for pressure fall, with mineral oils. Over these limits, phenomena such as cavitation, hose decompression effect (...) can appear. A positive inlet pressure and no inlet strainer are recommended to avoid a too high inlet vacuum.

7. Consequences of too high pressure gradients

- Cam ring fatigue rupture.



- Rotor and port plates seizure :
These are due to a very strong cavitation when the pressure decrease is dramatic. The sudden flow required is so important that the instant local velocity rises and creates the cavitation.



2.4. PHYSICAL, CHEMICAL OR HYDRAULIC FAILURES

All the following failure examples are linked, one way or another, to the quality of the lubricant, its poor filtration or the poor inlet conditions. Either there is some contamination (air, particles, water...), or some temperature problems, a poor oil edging, cavitation or fluid aeration.

1. Start-up without a proper air bleed-off

The vane pumps are designed and manufactured with a dry lubricant capability. The dry graphite lubricant coating on the cam ring and the surface treatment on the distribution plates are allowing a good lubrication during start-ups.

A good circuit priming and air bleed-off must be made before operating the pump under pressure.

- Without priming, the pump will not be lubricated enough and be damaged. The consequence of this bad lubrication is local overheating. Depending on how long this defect lasts, the consequences can go up to the seizure between the port plates and the rotor. The local temperature becomes so high that the film of oil between the components disappears, then, the metal to metal contact will create a friction leading to the "welding seizure".
- Without complete air bleed-off, the pump will not work properly. The pressure will not build up correctly, the flow could be lower than the one required, the pumping will be erratic and noisy.
- If the inlet velocity is too low, under 0,5 m/s, the air will stay trapped in the pump and in the inlet pipe.

2. Air contamination - Fluid foaming

When we talk about air in the oil, it is the simplification of a complex chemical transformation. What we will call air is more a mix of different gases than air. This explains why under pressure, these gases will implode and create a very high local temperature.

The pressure creates the ignition and the gases will combust at temperatures as high as 1300° C.

The result is the destruction of the fluid, giving it a black color and a "burnt" smell. This phenomenon is also known as the "Lorentz" or "Diesel" effect.

a) Aeration.

The phenomenon occurs when some air is brought into the system and, with the turbulences of the flows, generates a foamed substance.

This new "fluid" has lost all the requirements of the original fluid and, therefore, lost all the capabilities of a standard hydraulic fluid. The consequences of such a transformation are different depending on the quantity of air brought into the system.

Fluid aeration could be caused by different external problems, such as :

- A suction pipe under vacuum that is not sealed, therefore sucking air.
- A deteriorated shaft seal (or high radial load creating an air intake).
- An inlet tube in front of a return line (amplifying the foaming).
- A turbulence created by a high velocity around the inlet tube (not enough suction surface).

- A return line coming back to the reservoir above the oil level. It is required that the lowest point of a return line must always be below the oil level (five times the pipe diameter).
- An oil level in the tank that is too low compared to the suction level.
- A too small tank (high velocity in the tank).
- Fluid being in movement (bad tank design on mobile applications).
- Bad deaeration capabilities of the fluid and/or the tank. Baffles can help "pushing" the air to the surface. If the "vein flow" is too fast and if no baffle is there to bring these bubbles to the surface, they will reach the inlet side of the tank. This air going to the pump will deteriorate it.
- A bad baffle design. If the fluid is to pass over the baffle, its maximum speed has to stay under 0.5 meter per second to avoid turbulence.
- A Venturi effect on a return pipe.
- An anti-siphon hole drilled in a return pipe.
- water pollution that may create steam due to local overheating. This steam in contact with oil will create foaming.

b) Consequences of aeration :

The vanes are going to be completely unbalanced because of the abnormal fluid compressibility due to the quantity of air in the oil. Because of air, vanes usually hydrostatically balanced, will move sideways with such erratic movements that they will destroy their lubricant film of oil that links them to the port plates. Doing so, the vanes, as hardened metal parts, will start to wear the port plates made of die cast or ductile iron.

The marks will start in the discharge area and, depending on the quantity of air, will more or less create a groove. During all these turbulences, the most noticeable fact is an unusual noise level.

- Quantity of air is erratic or not really heavy :
The effects are only scores on the port plates in the suction area.



- Aeration is very severe : The groove will deeply mark the port plates, from the suction area to the outlet area. The width of the groove is then the width of the vane.

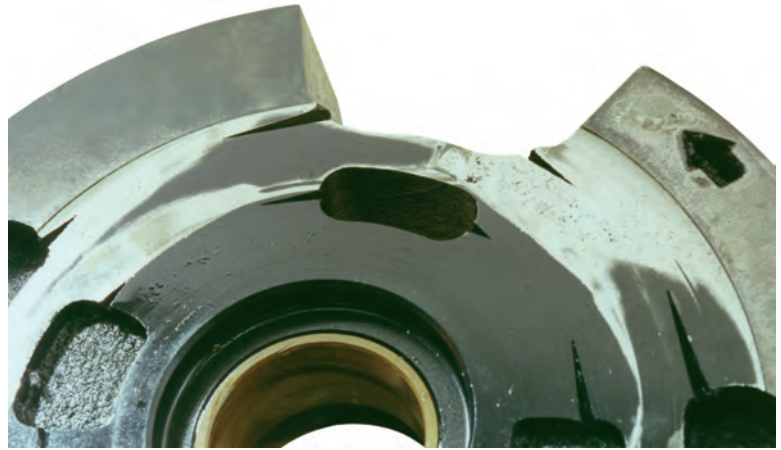

The vane is so unbalanced that, sometimes, it can even break.



The loss of balance of the vanes is generating very high instant accelerations of the pins. Pins hit the ring inside the rotor, up to its eventual destruction.



The pump is noisy.

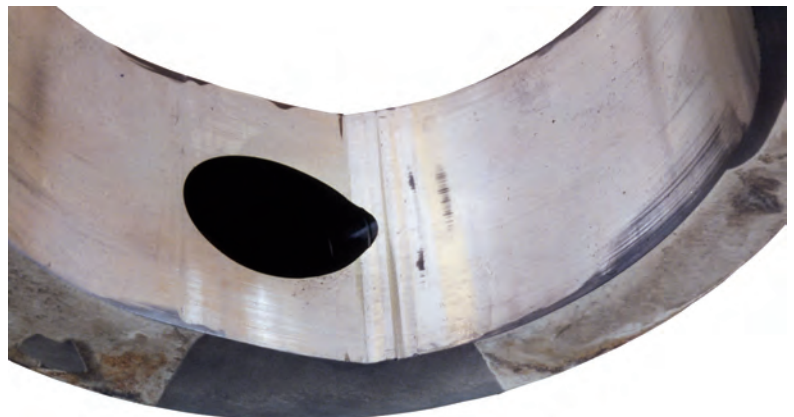

- Before obtaining such a disastrous wear, the vanes being so unsteady will make a lot of noise, the flow will not be the one required and/or the pressure level will not be obtained. The physical aspect of the oil will be "milky" on the surface as the oil and the air create a foam.

The accumulation of air in the push pin area leads to an unsteady behaviour, the pin is hammering the rotor ring till destruction by perforation.



c) Cavitation-Deaeration :

When a depression arises in the suction port, the gas (combustible) and the aromatic essences dissolved in the fluid (6 to 7 %) evaporate. Depending on the type of fluid, this deaeration will occur between 100 and 150 mmHg (around - 0.2 bar). Under this depression (or vacuum), small bubbles with a diameter of .2 to .3 mm will be formed. The natural appearance of oil is translucent. Under cavitation and because of these small "bubbles", the fluid will have a "cloudy" appearance. Depending on the value of the vacuum, the quantity of suspended bubbles will be more or less important. As these bubbles have a small diameter, they will reach the surface of the oil tank very slowly (bad deaeration characteristics). As an example, 100 liters of a foamed oil by cavitation will take 4 hours to become translucent again. When the fluid reaches local hot temperatures and the bubbles are compressed above their critical pressure, they implode and create a shock wave. Known as the Diesel effect, the impact of these "combustion explosions" will create erosion in the shape of the crater (cavities) when located near a metallic surface. These detached metallic particles are very likely to cause, on a medium term base, a seizure between the moving parts of the pump.

Cavitation – Deaeration can happen because of different external problems that can be independent or linked to each other, just like :

- Suction strainer clogged by a foreign contaminant.
- Suction strainer clogged by a too high viscosity.
- Suction strainer sized too small (Flow rate / pressure drop).
- Too long inlet Hose.
- Too small inlet line (with a too small section on the whole piping or restricted at one place only).
- Too high or too low inlet line velocity (Min. is 0,5 m/s and Max. is 1.9 m/s).
- Inlet pipe inside the tank which is too close from the side panel of the tank.
- Inlet pipe inside the tank with a too small suction surface, creating a local turbulence that deaerates the fluid (inlet pipe must always be cut with a bevel to avoid local high velocities).
- Tank having a too small volume that creates high fluid velocities in it.
- Tank located too far away from the pump (either horizontally or vertically).
- Tank with bad deaeration capability. No baffles or poor design of these, preventing the air to reach the fluid surface.
- Oil level of the tank that is installed too low compared to the suction level (check when all cylinders are extended for example).
- Air filter clogged or not correctly dimensioned, generating a vacuum inside the tank.
- Return line filter sized too small. Under dimension will increase the fluid velocity and may deaerate the oil.
- Excessive pump shaft rotating speed.

d) Consequences when the pump is cavitating :

- Noise level : much higher than usual. Under pressure, this noise level is amplified.



- Ripples on the cam ring : the vanes are hydrostatically balanced to avoid excessive loads on the vane lips. Under suction cycle, the pin compensates the out of balance load due to the cam profile. When the depression is over the design limits, the vane bounces, creating ripples on the cam ring profile. The depth of these marks is proportional to the strength of the depression.



- Craters : these erosion craters are sometimes difficult to observe as the pump may have already seized. They come from erosion, caused either by an explosion / implosion, or by depressurization. When the fluid trapped between two vanes is sucked in with a certain percentage of air in suspension, an explosion can occur. When this trapped volume is compressed, these air bubbles explode and create craters in the port plates in the area between the suction port and the pressure port, around the pressure bleed slots.



- Craters on a port plate



- Craters on a vane



- Craters on pins



- Black marks : The local depression consequences can be seen on the vanes (top lips and on the center of the vane), on the port plates (in the inlet area) and on the center of the cam ring (just after the inlet "feeding hole"). These black marks can be transformed into small craters in the port plates near the outlet bleed slots as the air bubbles explosion occurs.



- Seizure of the pump :

Due to a lack of fluid, the vacuum generated, when really severe, will suck the oil on the side of the pump (between the rotor and the port plates). This will have the effect of breaking the film of oil that lubricates these surfaces.

The surfaces will then heat up and this local overheat will modify the standard lubricity into a dry friction. The result is a seizure between the rotor and the port plates (the heavy contamination resulting from the digging of the craters can also badly lubricate the pump and lead to the seizure).

- Twisted torsionnal rupture due to rotor seizure, cartridge will be blocked and shaft rupture due to excessive torque loading.

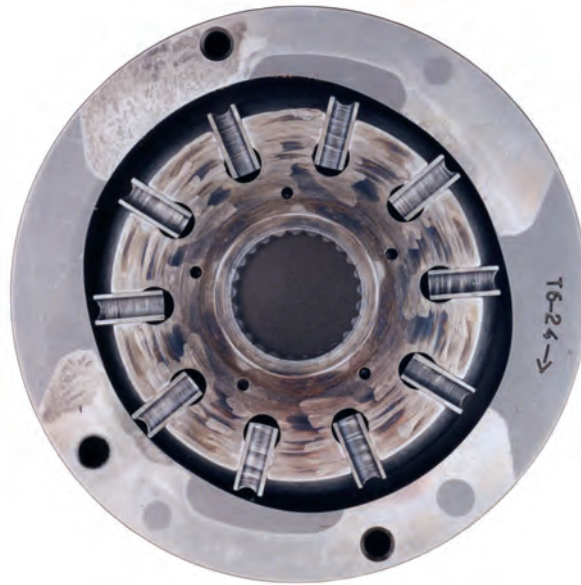

3. Solid particle contamination

Unlike many other technologies, the Parker vane units do not generate pollution.

Even if this has become an important topic and a lot of education has been done around fluid cleanliness, the pollution by particles stays one of the greatest causes of pumps' destruction. The consequences are either a rapid wear or a premature breakdown (large size particles over 25 µm). In a hydraulic circuit, the pump is the flow/pressure generator. Being so, it becomes the most sensitive unit to pollution and, therefore, will be the first component to fail.

Nature of the particles :

The main particles are made of metallic oxide, silica, carbon and organic materials.

Origin of the particles :

- A common large particle is the metallic oxide coming from welding burrs when the welded piping has not been cleaned up properly.
- The silica comes from the surrounding dust. This dust will enter into the system through cylinders' sealing, through air intakes (no air filter, a dirty environment, a not properly sealed tank...)

4. Consequences of solid particles contamination

- Vanes :

- On the vane lip edges : The particles in the fluid will have a grinding effect between the top of the lip and the cam ring profile. When the contaminant is too big or too stiff, the vane lip edges can break.

- On the vane surface : The film of oil between the vanes and the rotor being contaminated, there will be a rubbing effect in this area. These rubbing marks (pollution marks) will be vertical and of the height of the vanes translation (displacement).

Depending on the size of the particles, the consequences can go from a gentle ground finish on the vane lips, cam surface and side plates to the total destruction of the cartridge.

It is obvious that under perfect filtration conditions, the rubbing of the vanes in the rotor is reduced to a minimum by the action of the oil under pressure which is located all around the vanes.

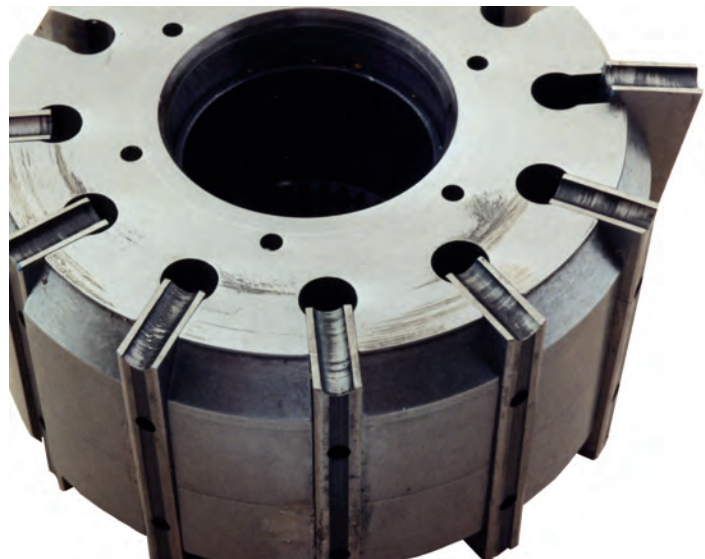

- Cam ring :

- Wear of the inner surface of the cam ring due to the contaminated oil film between vane lip and cam ring.

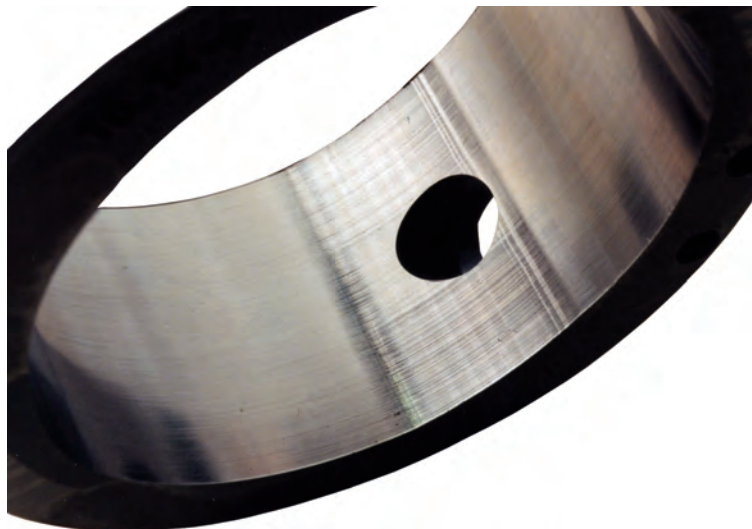

- Wear on the edge of the cam ring contour (has a slight chamfer when new), you will find a sharp angle (edge). If the wear is heavy, the cam ring can also have little burrs in this area.

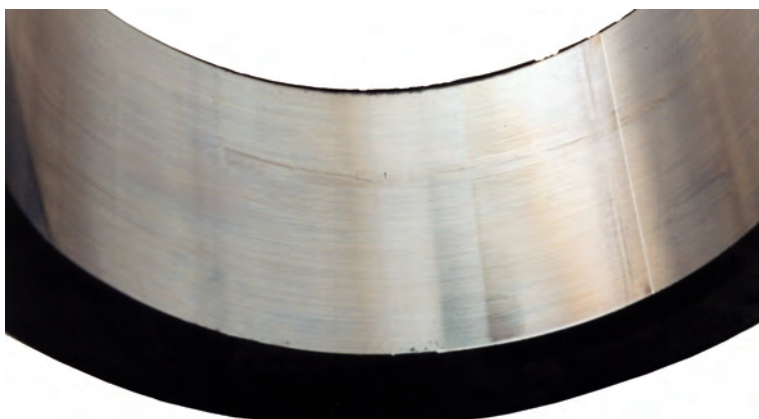

- Rotor and vanes :

In the rotors' slots, the rubbing wear between the slots and the vanes will also lead to pollution marks.



Physical, chemical or hydraulic failures

- Rotor and port plates :
When the particles in suspension in the fluid are greater than half of the clearance between the thickness of the rotor and the thickness of the cam ring, seizure occurs in the peripheral diameter of the rotor and the port plates.



- Rotor : The rubbing effect will also appear between the side of the rotor and the port plate. This will create a torque between the two vane slaps. This torque causes a reasonably high level of fatigue in the material's weakest area, between the two bulb slots of the rotor. If this fatigue level exceeds the design limits, this portion of the rotor breaks'.



- Rotor, vanes and port plates : Large contamination particles damages (like "carbon" welding balls) are usually seen on the port plates (blocked in the slots) or/and on the top of the vanes/rotor. Each time, they will have an effect on the vane lips, either on their top or on their sides. The "rubbing" action will either destroy the vane lips or weld the vane to the rotor, break the cam ring...

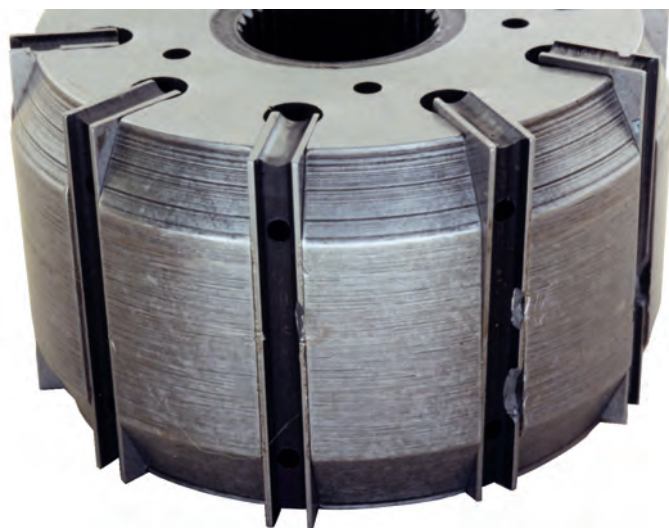

- Port plates :

Another sign of contaminated oil is some possible erosion craters on the port plates at the inlet/suction bleed slots area. These erosion craters would come from the abrasive fine particles in a local high velocity area.



5. Water contamination

Depending on the type of fluid, the water contamination limit can be different. For mineral oils, this limit should not exceed 1000 ppm (particles per million). The limit for the esters and the vegetable oils is maximum 500 ppm. The water contamination will modify the chemical structure of the fluid (the oxidation of the fluid increases the TAN (Total Acid Number)). Having an excess of water, this water can be transformed into steam under the action of the pressure. Another effect of this excess is the modification of the "compressibility module".

When contaminated by water, the fluid will lose its characteristics/performances. The oxidation of the fluid will modify the TAN (Total Acid Number) and a higher acidity will destroy the additives. Destroying the additives means the lubricity will be worse and the thermic stability very poor. This, added to the local heat created, will transform (or carbonize) the fluid. It will modify its molecular structure. The colour of the fluid will turn creamy (milky).

The excess of water can also bring in bacteria that can damage the fluid. A gelatinous mass in the tank and in some components is a way to observe this phenomenon. The most common consequence is the appearance of rust on all metallic surfaces, modifying the nature of the contacts between the surfaces. This can lead to a start of local micro-seizures due to a lack of convenient lubricant.

When polluted with water, the whole system must be cleaned up and then drained two or three times until obtaining a clean translucent oil when running.

This water pollution can come from various causes :

- Condensation coming from a high hydrometric level (big temperature variations).
- A leak in the water exchanger.
- A tank that is not water-tight.
- A storage of the oil barrels outside, in a vertical position.
- During high pressure water cleaning of the machines (ex. : water going under the seals of cylinders on vehicles).

6. Consequences of water contamination

- Deposit can then be seen on the vanes. This will modify the performances of the pump because of the deterioration of the mechanical efficiency (the deposit will "stick" the vanes in the slots of the rotor).

- On the cartridge, it changes the colour of the bronze bushing (due to the modification of the acidity) and leaves a deposit on the external diameter.

- The fluid can produce foaming because of the steam. The specificity of the foaming oil due to water is a milky or creamy typical aspect. The consequences are identical to an aerated fluid.

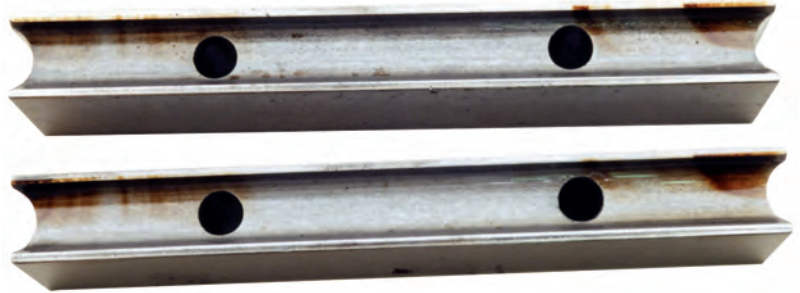

- The fluid compressibility will fluctuate and therefore destabilize the vanes. This will be seen on the cam ring surface having plenty of ripples and on the sharp vane lips edges. In such a case, the noise level will be high and the flow & pressure capabilities deteriorated.

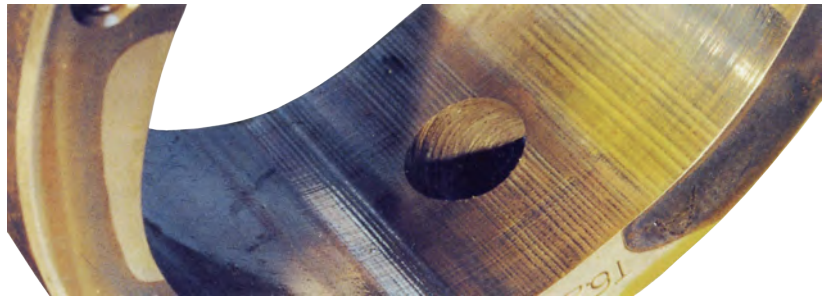

- Due to these fluid transformations, the mechanical consequences range from performance being deteriorated to the destruction of the pump if the local temperatures are extreme (picture showing, phosphate oil additive deposit).

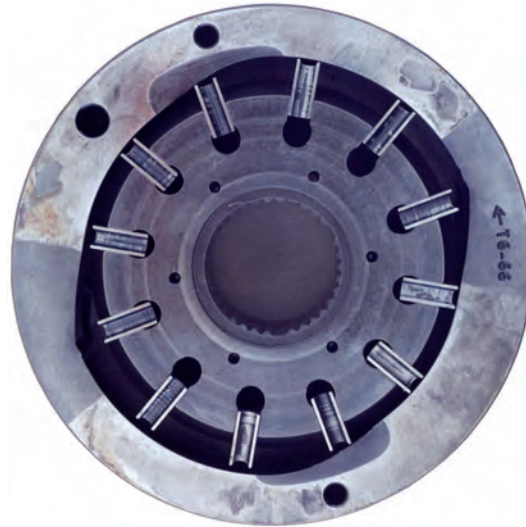

7. Viscosity failures

The environment and the temperatures can considerably modify the original wanted viscosity. The influence of the temperature differences on the viscosity is enormous. The vane components are designed to work with a wide range of viscosities. When a problem occurs, the viscosity is often either too high or too low.

When the viscosity is too high, over 2000 cSt (9240 SSU), the problem is that the fluid has a big resistance and the velocity drops down. This resistance can create local vacuum, that is to say deaeration of the fluid. This will ruin the lubricity of the pump.

Under heavy viscosity and low rotation speed, the vanes can stick and remain stuck in the rotor slots. The consequence is that there is no flow coming out of the pump.

When the viscosity is too low, under 10 cSt (60 SSU), it decreases the thickness of the film that lubricates all the components in motion. If the viscosity is very low, it could mean that the temperature is high. Tests carried out have shown that a tank temperature of 50° C (122° F) could mean local temperatures inside the pump of up to 130° C (266° F). If the viscosity is calculated on the tanks temperature, we can easily figure out the very low viscosity when the oil is at 130° C (266° F).

8. Consequences of viscosity failures

- Too high viscosity : Seizure due to the high cavitation not allowing the rotating group to be lubricated.



- Too low viscosity : Erosion on the port plates.

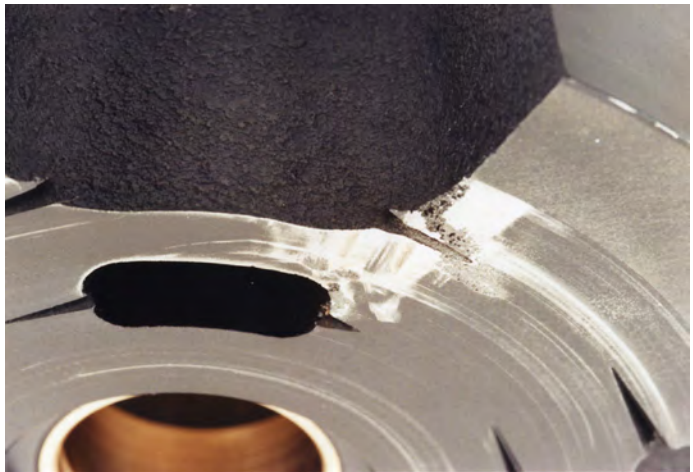

- Too low viscosity : Scars on the port plates & rotor due to a bad lubricity.



9. Unsuitable fluids

- Viscosity index choice :

The choice of the fluid has to take into consideration the specific environment of the application.

Forgetting this can lead into deep trouble. A too high viscosity will probably cause cavitation and a lack of lubrication, when a too low viscosity will lead to a too thin film of oil therefore creating local heat points. In both extremes, the consequences can be fatal breakdowns.

- Filterability :

If the fluid does not have good filterability properties, the filters will rapidly get clogged. The flow will have to go through the by-pass, therefore not be filtrated anymore, and will heat-up the system (due to the open by-pass).

Bad filterability can either come from a low quality fluid, or from a fluid sensitive to any contaminant destroying its chemical homogeneity (water, solvents, grease...).

- Oxidation resistance :

Contaminants can modify the acidity of the fluid therefore becoming very corrosive. Such a modified fluid will corrode the steel components and produce corrosion residues. These residues will increase the viscosity. An increased viscosity will increase the pressure drops. Increased pressure drops will then increase the temperature and cause local overheat.

- Deaeration capabilities :

This is another very important topic. If the chosen fluid is taking a too long time to allows the air to reach the surface of the tank, this can become a big problem, for air in big quantities has a destroying effect on all pump technologies. If the flow versus the size of the tank is small, if the tank design is incorrect (inlet near return line for example), if the tank is slightly pressurized (on purpose), the oil will not deaerate fast enough. The air bubbles will then be sucked by the pump. Then, when under pressure, these bubbles will explode.

- Polluted fluid :

This is a major topic, well known nowadays, at least for the solid particle contamination. The manufacturing clearances becoming tighter and tighter, a good filtration is required, even despite our double lip technology which is fairly well resistant to pollution.

One more important point is the impact of another fluid creating a reaction between the original fluid and the contaminant.

The fluids are becoming more and more high technical products, they also tend to be more sensitive to their environment and a contaminant can destroy their original characteristics. It is common for example to see fluids "destroyed" by a high water content (chemical, other fluid, particles). Refined oils will be even more sensitive than brand new ones.

- Density :

It is important to know the specific gravity of the fluid being used. Because the density from one fluid to another can vary a lot, the suction head has to be designed taking this parameter into account. The specific gravity of a standard oil (ISO 46) will be around 0.88. The specific gravity of a water-glycol (60 glycol/40 water) will be around 1.08. Knowing this value, simply check in our catalogue the minimum Absolute pressure value required to optimize your system.

- Fluid deterioration over time :

A common problem is the deterioration of the fluid. This deterioration may come either from the quality of the fluid, or from the air, or from external pollution (solid particles, mix with other fluids, chemical transformations, water). The consequences of fluid deterioration always lead to a low performing pump or to a premature breakdown.

10. Unsuitable grease

- Bad lubricant on the shaft and coupling assembly :

We recommend for all grease lubricants to be based with disulfide or molybdenum. The main characteristics of this grease is that it is the best for heavy duty applications. It has a very good specific load characteristic, avoids stickslip and fretting corrosion, has a good penetrability and enables easy dismantling.

3. SPECIFICS OF VANE MOTORS FAILURES AND CAUSES

For the motor being an actuator in an hydraulic circuit, the incidents are not very common. Therefore it will be much easier to go through the various typical vane motors failures you can possibly be facing.

Exploded views of vane motors and cartridges

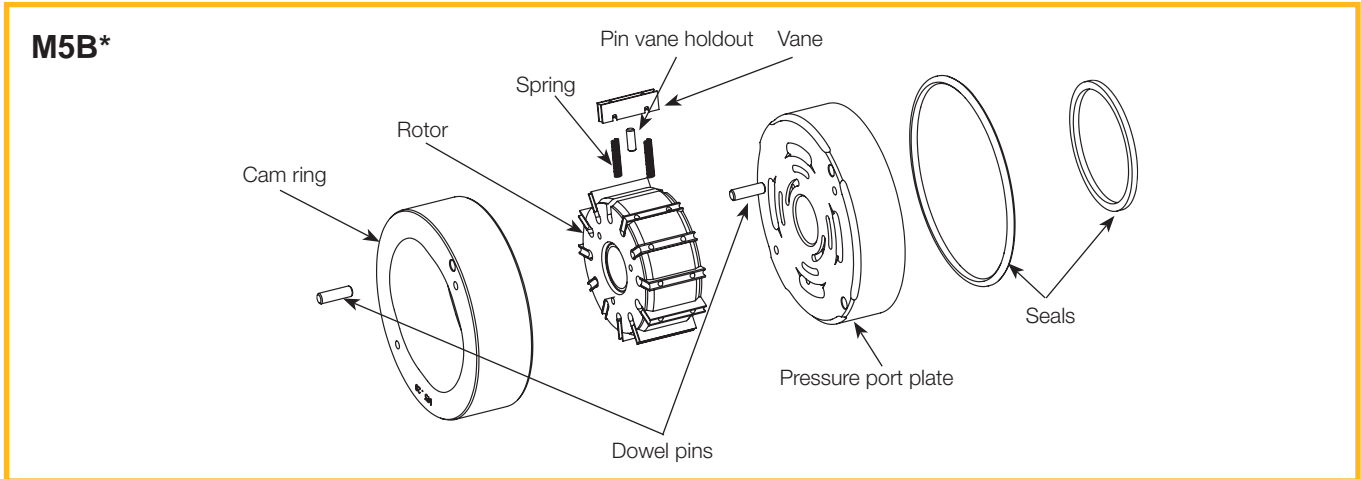
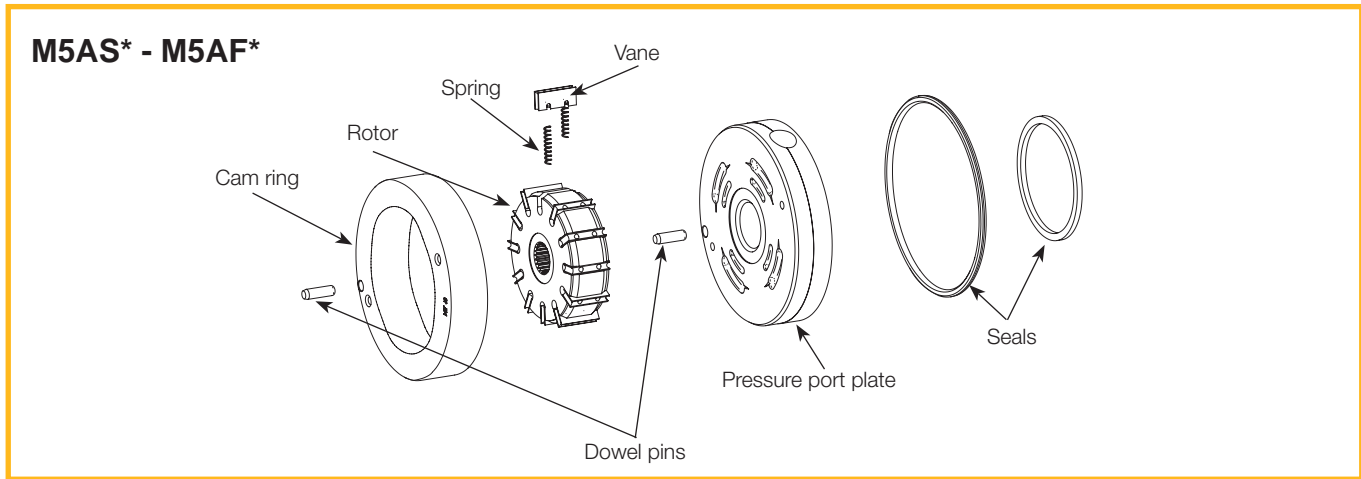
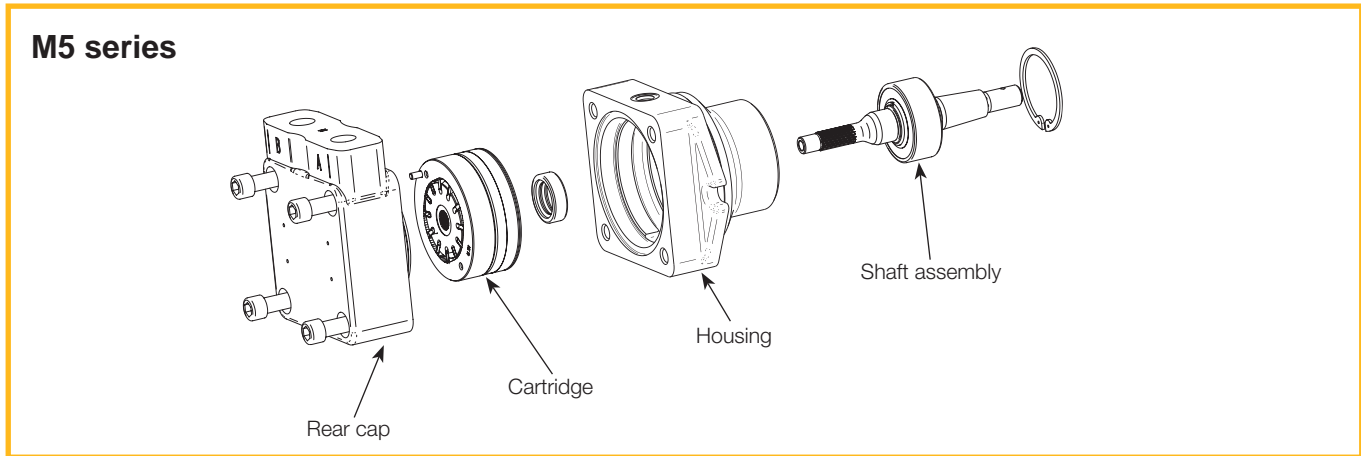

3.1. TORQUE OVER THE CATALOGUE LIMITS

- Front shaft end rupture.



- Internal splines distortion.

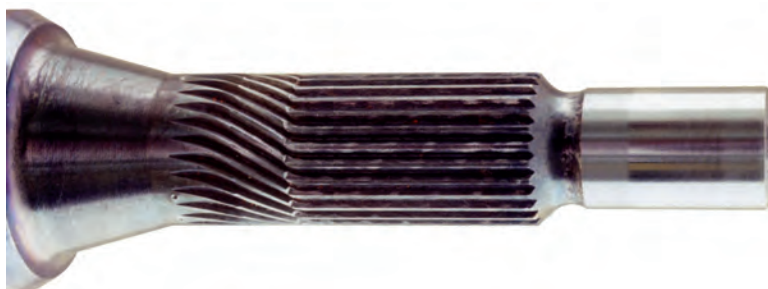

3.2. BAD AIR BLEED-OFF OR AIR INTAKE

- Incorrect rear cap lubrication.
Possible seizure between the rotor and the rear cap.

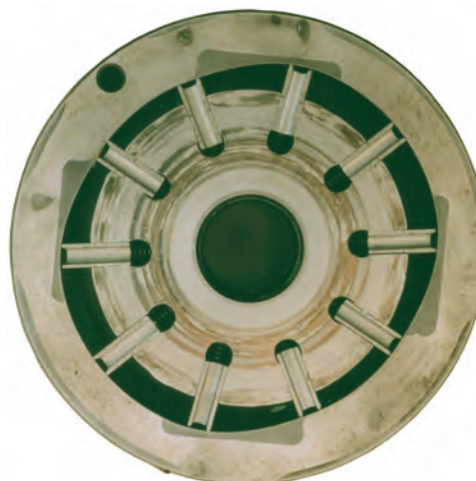

3.3. TOO HIGH PRESSURE IN A OR B LINE

- Rotor rupture.

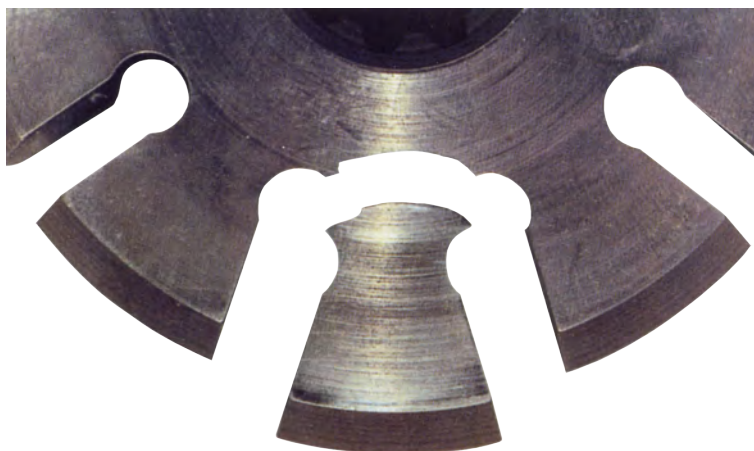

- Port block cracked.



3.4. TOO HIGH PRESSURE IN THE DRAIN LINE

- Shaft seal blown off (extruded).



3.5. EXCESS OF AIR IN THE FLUID

Air coming from the system, from an intake between the pump and the motor, or even coming from a front shaft seal.

- Possible seizure between the rotor and the rear cover.
- Possible heavy wear on the port plate.



3.6. CAVITATION

The speed of the motor is higher than the flow coming to the motor.

- Heavy cavitation will lead to seizure.

- Broken springs due to cyclic "erratic movements" of the vanes during cavitation phases.

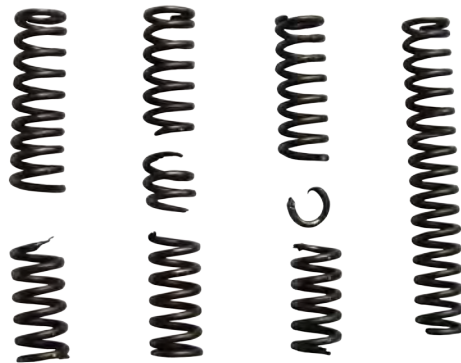

3.7. POLLUTION

The consequences of pollution will be seen at various places :

- On the sides of the rotor, the port plate and the rear cap.

- In the rotor slots : Grinding on both sides of the slots. Traces of the "spring areas" of the vanes digging in.

- On the vanes : One large particle (welding ball) and small vertical scars.

- In the cam ring : Scars due to large particles.

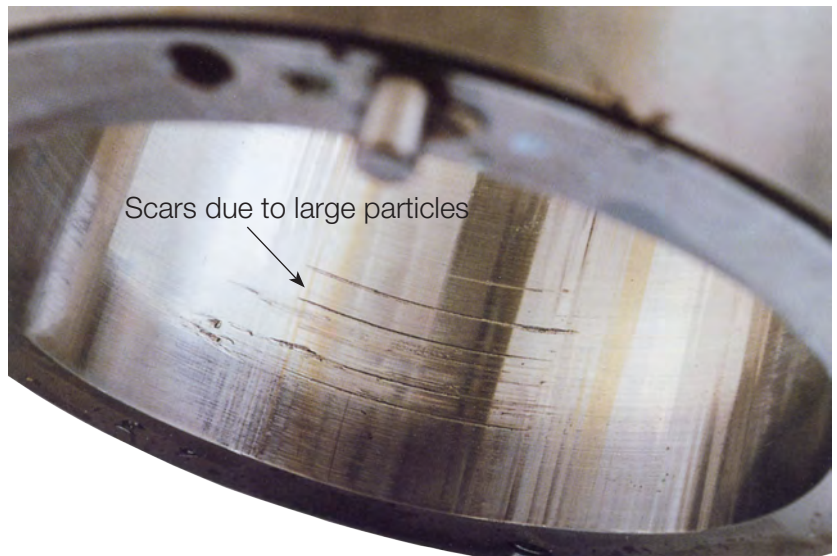
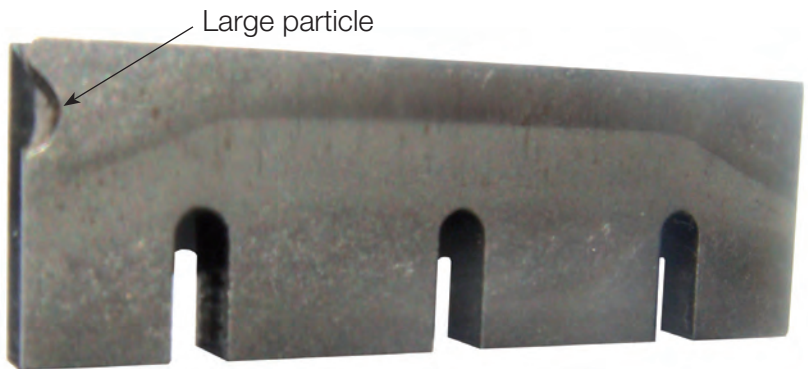
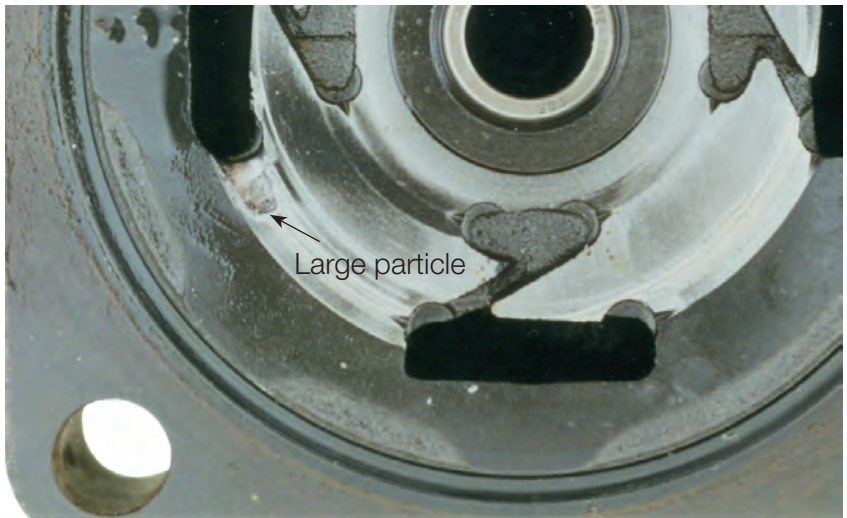

3.8. TOO LOW VISCOSITY

When the temperature rises and the fluid viscosity drops below limits, the film of oil required to lubricate the components will possibly be too thin. Microseizures leading to total seizure is a potential consequence.

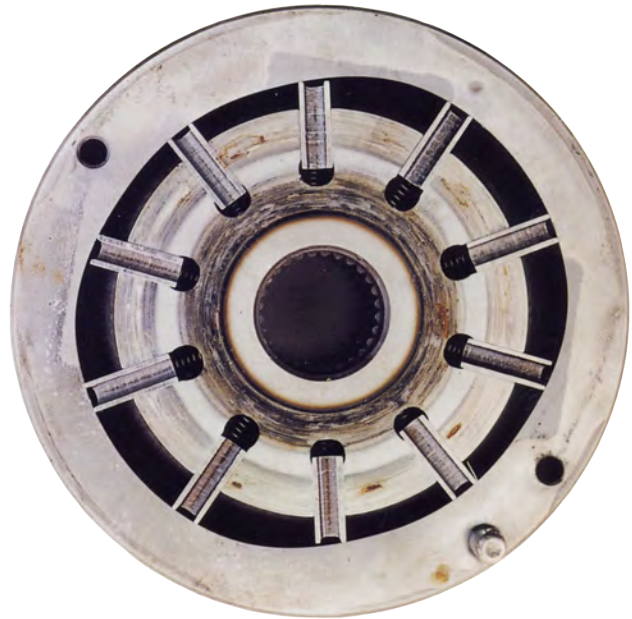

CONCLUSION

The Denison Vane Technology of the Parker units is axially and radially hydrostatically balanced, offering from design very long lasting capabilities.

The quality of our vane products is certified by factory testing each and every vane pump or motor before shipment.

Our experience has shown us that if :

- Inlet characteristics
- Operating limits (pressure, rpm, viscosity...)
- Mechanical alignments
- Quality and cleanliness of the fluid (at all time)

remain within the limits given in our catalogues, you are sure to obtain a high performing and long lasting pump/motor. These few requirements are the major parameters to check with the values indicated in our catalogues.

TROUBLESHOOTING CHARTS

4. TROUBLESHOOTING CHARTS

This chapter 4 will help you when the hydraulic system or component does not work as required. These solutions are the most common ones we found and experienced in the field.

Please always remember that a clean system and a correct air bleed-off may solve a lot of incidents.

There are 3 tables for the 3 following product families, vane pumps, M3 / M4 series vane motors, M5* series vane motors, and one table for the separate components.

4.1. TROUBLESHOOTING TABLE FOR VANE PUMPS	50
1. No flow, no pressure	50
2. Flow below rated	50
3. No pressure	51
4. Not enough pressure	52
5. Unusual noise level	52
6. Unusual heat level	52
7. Shaft seal leakage	53
4.2. TROUBLESHOOTING TABLE FOR VANE MOTORS - M3* / M4* SERIES	54
1. No rotation	54
2. Stalls easily	54
3. Not enough speed	54
4. Erratic speed	54
5. Unusual noise level	55
6. Unusual heat level	55
7. Shaft end leakage	55
4.3. TROUBLESHOOTING TABLE FOR VANE MOTORS - M5* SERIES	56
1. No rotation	56
2. Stalls easily	56
3. Not enough speed	56
4. Erratic speed	56
5. Unusual noise level	57
6. Unusual heat level	57
7. Shaft end leakage	57

4.1. TROUBLESHOOTING TABLE FOR VANE PUMPS

<p>1. No flow, no pressure</p>	<p>a) Is the pump rotating ?</p>	<p>a-1) Check if the coupling is rotating. If not, check the rotation of the electric motor. a-2) Check the keys of the pump and the motor or engine shaft. a-3) Check if the shaft is not broken.</p>
	<p>b) Is the rotation in the correct direction way ?</p>	<p>b-1) Check if the rotation way of the pump is corresponding to the arrow on the name plate. b-2) Check if the wiring of the electric motor is correct.</p>
	<p>c) Is the air bleed-off done ?</p>	<p>c-1) Check that no air remains in the pressure line.</p>
	<p>d) What are the inlet conditions ?</p>	<p>d-1) Check if the inlet gate valve is not closed. d-2) Check the oil level. d-3) Make sure the inlet pipe in the tank is well under the oil level. d-4) Check that no air intake may disturb the inlet (missing inlet flange seal, air trapped in suction line). d-5) Check if the pump is not located too high above the oil level. d-6) Check if the tank is not completely sealed. Then the lack of atmospheric pressure will not allow the pump to prime. d-7) Make sure that all connections and seals are air-tight.</p>
	<p>e) Is the viscosity not too high ?</p>	<p>e-1) Check that the oil characteristics are in accordance with the temperature and the pump requirements. A too high viscosity will "stick" the vein fluid, not enabling the pump to suck the oil correctly.</p>
	<p>f) Is the pump flow not going somewhere else ?</p>	<p>f-1) Check the hydraulic circuit and the main sequences. Doing so, you will check if all the valves are set or work properly. f-2) Check if the main relief valve is not set at an extremely low pressure, therefore bringing all the flow back to the tank. f-3) Check if in the directional valves the spools are not sticking in a position that brings the flow back to the tank. f-4) check that no check valve is mounted «upside down».</p>
	<p>g) Is the actuator working correctly ?</p>	<p>g-1) Motor : Check whether the inlet flow does not leak internally. g-2) Cylinder : Check if the inner seals are not damaged.</p>
	<p>h) Is the speed high enough ?</p>	<p>h-1) Check if the minimum speed is reached. (See pump documentation)</p>
<p>2. Flow below rated</p>	<p>a) Are the components OK ?</p>	<p>a-1) Check the displacement of the pump. a-2) Check if the speed of the pump is not too low or too high (Correct type and size of the E motor or engine, eventual speed drops, or stalls). a-3) Check if the main relief valve is not set at an extremely low pressure and therefore venting some flow back to the tank. a-4) Check if in the directional valves the spools are not sticking in a position that brings part of the flow back to the tank.</p>

<p>3. No pressure</p>	<p>b) Is the connection from the tank to the pump correct ?</p>	<p>a-5) Check if the hydraulic motor is not leaking internally due to a bad efficiency, low viscosity...</p> <p>a-6) Check if the cylinder inner seals are not ruined, allowing internal leakage.</p> <p>b-1) Check if there is no air intake between the pump and the inlet pipe (bad seals for example).</p> <p>b-2) Check if the inlet line is suitable for the required velocity ($0,5 < V < 1,9$ m/s).</p> <p>b-3) Check if the pump is not located too high compared to the oil level or if the pump is not too far from the tank (check the inlet pressure with the values in the catalogue).</p> <p>b-4) Make sure the gate valve is fully open.</p> <p>b-5) Check that the eventual inlet strainer is correctly sized (250 μ mesh mini.) and not clogged.</p>
	<p>c) Is the tank design correct ?</p>	<p>c-1) Check if the oil level is correct.</p> <p>c-2) Make sure to check if the suction pipe remains under the oil level at all time during the complete cycle of the machine.</p> <p>c-3) Check if the inlet pipe fitted in the tank is cut with an angle wider than 45°.</p> <p>c-4) Check if this inlet pipe is not too close to the side wall or the bottom of the tank, therefore limiting the "vein flow".</p> <p>c-5) Check if the suction pipe is not located too near the return line, therefore sucking a lot of air coming from these turbulences.</p> <p>c-6) Check if baffles are required to allow correct deaeration of the fluid.</p> <p>c-7) Check if the air filter is not clogged or undersized.</p> <p>c-8) Check if the tank is not fully air-tight, hence not allowing the atmospheric pressure to apply.</p>
	<p>d) Is the oil type suitable ?</p>	<p>d-1) Check if the oil characteristics are in accordance with the pump requirements.</p> <p>d-2) Check if the viscosity is not too high, therefore «sticking» some vanes in the rotor or blocking the vein fluid.</p> <p>d-3) Check if the high temperature does not make the viscosity of the fluid drop, increasing the internal leakages.</p>
	<p>a) Is the hydraulic circuit correctly designed ?</p>	<p>a-1) Check the hydraulic circuit schematic.</p>
	<p>b) Is the circuit correctly piped ?</p>	<p>b-1) Compare the schematic to the existing circuit.</p>
	<p>c) Are the components working properly ?</p>	<p>c-1) Check the main sequences. Doing so, you will check if all the valves are set or work properly.</p> <p>c-2) Check if the main relief valve is not set at a low pressure value, therefore bringing all the flow back to the tank.</p> <p>c-3) Check if in the directional valves the spools are not sticking in a position that brings the flow back to the tank.</p>

Troubleshooting charts for vane pumps

<p>4. Not enough pressure</p>	<p>a) Same check as "no pressure".</p> <p>b) Is the system well dimensioned ?</p> <p>c) Is there an internal leakage somewhere that maintains a certain pressure ?</p>	<p>b-1) Check if the required flow is not over the available flow and therefore cannot build up enough pressure.</p> <p>c-1) Check all the possible faulty components, from the pump to the actuators and intermediates (high pressure seals, mechanical wear...).</p>
<p>5. Unusual noise level</p>	<p>a) Is the noise coming from the pump ?</p> <p>b) Is the noise coming from the surroundings ?</p>	<p>a-1) Check the mechanical link of the pump shaft : alignment, balancing of the coupling or Universal joint, key properly fastened...</p> <p>a-2) Check if the air bleed-off has been done correctly.</p> <p>a-3) Check if there is no air intake from the tank to the pump (nor through the shaft seal).</p> <p>a-4) Check if a hose strain force does not create this noise.</p> <p>a-5) Check if the oil level is correct.</p> <p>a-6) Check if the oil inside the tank is not aerated.</p> <p>a-7) Check if the eventual strainer is not clogged or under-dimensioned.</p> <p>a-8) Check if the inlet pipe is well below the oil level.</p> <p>a-9) Check if the air filter is not clogged or too small.</p> <p>a-10) Check if the rotating speed is in accordance with the catalogue limits.</p> <p>a-11) Check if the oil type is compatible with the catalogue recommendations.</p> <p>a-12) Check that the inlet pressure is not higher than the outlet pressure.</p> <p>b-1) Check the hoses and see if the noise is not coming back to the pump by this way.</p> <p>b-2) Check the pressure piping and see if its length dumps or amplifies the noise.</p> <p>b-3) Check if the structure of the tank is stiff enough to avoid amplification / resonance.</p> <p>b-4) Check the E motor fan.</p> <p>b-5) Check the balancing of the E motor.</p> <p>b-6) Check the water cooler and its theoretical limits.</p> <p>b-7) Check the filtration unit, its capacity and if the noise does not come from an opened by-pass valve.</p>
<p>6. Unusual heat level</p>	<p>a) Does the heat rise occur when the pump is running without pressure ?</p>	<p>a-1) Check the oil level and the suction pipe. Is the oil coming to the pump (check the length of the pipe, its internal diameter, all that could influence the inlet pressure)?</p> <p>a-2) Check if the air bleed-off has been done correctly.</p> <p>a-3) Check if the flow versus the volume of oil in the tank is correct to obtain a good cooling effect.</p> <p>a-4) Check if a cooler is required or, if there is one, if it is well dimensioned.</p> <p>a-5) If there is a cooler, check if it is working (example for a water</p>

Troubleshooting charts for vane pumps

<p>7. Shaft seal leakage</p>	<p>b) Does the heat rise occur when the pump is running with pressure ?</p>	<p>cooler : is the water flow open and sufficient ?). a-6) Check if the hydraulic circuit is not bringing back the flow directly to the inlet port. Doing so, it would create a very small closed circuit not able to cool down the fluid. a-7) Check the quality of the fluid. a-8) Check the velocity of the fluid. a-9) Check the filtration unit, its capacity and if the heat does not come from an open by-pass valve or if it is under-dimensioned (bigger delta P).</p>	
	<p>b-1) Check the viscosity. b-2) Check the pressure rating. b-3) Check if the cooler is working correctly and is well dimensioned. b-4) Check if the relief valve is not creating this heat. b-5) Check if any other component in the system is not creating this heat due to an internal defect. b-6) Check if there is a big temperature differential between the inlet and the outlet.</p>		
	<p>a) Is the seal leaking ?</p>	<p>a-1) Check the alignment of the front shaft and check if there is not any radial load. a-2) Check if seal lip has not been cut during a maintenance operation. a-3) Check if the inlet pressure is not over or under the catalogue values. This has to be done during a whole cycle because the inlet pressure can vary from time to time. a-4) Check if the seal material has not been modified because of a too warm environment. The seal can vulcanize and stop sealing correctly. a-5) Check the acidity of the oil that can «burn» the seals material. It will therefore destroy the elasticity of the sealing. a-6) Check if the chosen seal (high pressure seal for example) is not too stiff for the use. If the environment requires some elasticity due to a gentle misalignment, a high pressure seal may not be able to follow the movement and therefore leak.</p>	<p>b-1) Check the alignment and the correct power transmission (non homokinetic movement, high radial force as examples). b-2) Check the inlet pressure and compare it to the catalogue values. b-3) Check if some bad suction conditions do not create a vacuum that could even reverse the seal lip. b-4) Check if the external environment is not too dirty and therefore ruining the seal.</p>

4.2. TROUBLESHOOTING TABLE FOR VANE MOTORS - M3* / M4* SERIES

1. No rotation	a) Is the flow coming to the motor ?	a-1) Check the circuit and the hydraulic schematic. Is the piping O.K.? a-2) Check the setting of the main pressure relief valve. a-3) Check if the pump is delivering flow. a-4) Check if the directional valve is allowing the flow to go to the motor. Check if the directional valve is energized. If it is, check if the spool is in its correct position and not sticking in a position that would deviate the flow somewhere else. a-5) Check if a check valve would not have been wrongly mounted.
	b) Is the torque required higher than the system settings ?	b-1) Check if the pressure settings are correct. b-2) Check if the load is not superior to the torque capabilities of the motor.
	c) Is the pump OK ?	c-1) Check if the pump is working correctly.
	d) Are the motors internal drain check valves working properly ?	d-1) Check if a failing check valve would not allow some flow to go back to the tank and therefore limit the flow to the motor.
	e) How is the motor piped ?	e-1) Check the nature of the connectors. If, for example, the “self sealing couplings” type connectors are well fitted into each other.
2. Stalls easily	a) Is the load close to the limits of the system ?	a-1) Check the relief valve setting and compare it to the theoretical pressure required to deliver the convenient torque.
	b) Are the motors internal drain check valves working properly ?	b-1) Check if a failing check valve would not allow some flow to go back to the tank and therefore limit the flow to the motor.
	c) Is the flow going to the motor sufficient ?	c-1) Check the minimum flow required by the motor. c-2) Check the flow of the pump or the valve feeding the motor.
3. Not enough speed	a) Is the speed lower than desired ?	a-1) Check the theoretical displacement of the motor versus the theoretical flow of the pump. a-2) Check that the flow of the pump is really coming to the motor. a-3) Check that the working pressure & speed are in accordance with the catalogue values of the motor. a-4) Check the oil temperature. Check then that the low viscosity of the oil is not having a big effect on the internal leakage of the motor. a-5) Check the air bleed-off.
4. Erratic speed	a) Is the motor loosing speed erratically ?	a-1) Check if the limit of the allowable torque is not reached once a while. a-2) Check if the driven load does not transmit some inconstant load (like a high pressure piston water pumps using an unbalanced technology).

Troubleshooting charts for vane motors

<p>5. Unusual noise level</p>	<p>a) When the motor is running ?</p>	<p>a-3) Check if the flow coming from the pump is constant.</p> <p>a-1) Check if there is no air intake aerating the motor badly (through the front shaft seal for example). a-2) Check if the motor is not cavitating. It could be that the inertia of the load is such that it drives the motor faster than the flow coming from the pump. a-3) Check if the oil is suitable for the use. a-4) Check if the air bleed-off has been done properly.</p> <p>b-1) Check the back pressure to see if the replenishment pressure is not too low, leading to cavitation of the motor.</p>
<p>6. Unusual heat level</p>	<p>a) Is the oil arriving to the motor already hot ?</p>	<p>a-1) Check if a cooler is required or, if there is one, if it is well dimensioned. a-2) If there is a cooler, check if it is working (example for water cooler : is the water flow open or sufficient ?). a-3) Check if the hydraulic circuit is not bringing back the flow directly to the inlet port. Doing so, it would create a very small closed circuit not able to cool down the fluid. a-4) Check the quality of the fluid. a-5) Check the velocity of the fluid (5 to 6 meters/second max.). a-6) Check the filtration unit, its capacity. a-7) Check if the heat does not come from an open bypass valve.</p> <p>b-1) Check the speed of rotation versus the catalogue values. b-2) Check the pressure rating. b-3) Check the fluid type. b-4) Check the viscosity.</p>
<p>7. Shaft end leakage</p>	<p>a) Is the seal leaking when pressurized ?</p> <p>b) Is the seal leaking when standing still ?</p>	<p>a-1) Check if the lips of the seal are not ruined (lack of lubricity leading to vulcanization of the rubber, external pollution...).</p> <p>a-2) Check if the shaft is not marked by a groove in the usual seal lip contact area. a-3) Check the shuttle valve. a-4) Check the pressure in the drain line on the motor. Long piping, elbows, small diameter, too high oil viscosity, other common drain flows in the same pipe can lead to high drain pressures. a-5) Check if there is no high overshoot at start-up that would create a high instant internal leakage. a-6) Check, when using a "quick coupling connector", if it is correctly locked. a-7) Check the alignment of the shafts. a-8) Check if there is no unbalanced driven load that could create a gap between the shaft and the seal. a-9) Check if the radial force is not too high (belt drives for example).</p> <p>b-1) Check that the seal is not damaged. b-2) Check that the shaft does not have any scratches. b-3) Check that the ball bearing is not ruined. b-4) Check that the drain line does not create a back pressure.</p>

4.3. TROUBLESHOOTING TABLE FOR VANE MOTORS - M5* SERIES

1. No rotation	a) Is the flow coming to the motor ?	a-1) Check the circuit and the hydraulic schematic. Is the piping O.K.? a-2) Check the setting of the main pressure relief valve. a-3) Check if the pump is delivering flow. a-4) Check if the directional valve is allowing the flow to go to the motor. Check if the directional valve is energized. If it is, check if the spool is in its correct position and not sticking in a position that would deviate the flow somewhere else. a-5) Check if a check valve would not have been wrongly mounted.
	b) Is the torque required higher than the system settings ?	b-1) Check if the pressure settings are correct. b-2) Check if the load is not superior to the torque capabilities of the motor.
	c) Is the pump OK?	c-1) Check if the pump is working correctly.
	d) How is the motor piped ?	d-1) Check the nature of the connectors. If, for example, the "self sealing quick couplings" type connectors are well locked into each other.
2. Stalls easily	a) Is the load close to the limits of the system ?	a-1) Check the relief valve setting value and compare it to the theoretical pressure required to deliver the convenient torque.
	b) Is the flow going to the motor sufficient ?	b-1) Check the minimum flow required by the motor. b-2) Check the flow of the pump or the valve feeding the motor.
	c) Is the anti-cavitation valve closed ?	c-1) Check that the valve is OK (properly installed, ball seat pollution).
3. Not enough speed	a) Is the speed lower than desired ?	a-1) Check the theoretical displacement of the motor versus the theoretical flow of the pump. a-2) Check that the flow of the pump is really arriving to the motor. a-3) Check that the working pressure & speed are in accordance with the catalogue values of the motor. a-4) Check the fluid temperature. Check then that the low viscosity of the fluid is not having a big effect on the internal leakage of the motor. a-5) Check the air bleed-off.
4. Erratic speed	a) Is the motor loosing speed erratically ?	a-1) Check if the limit of the allowable torque is not reached once a while. a-2) Check if the driven device does not transmit some inconstant load. a-3) Check if the flow coming from the pump is constant.

Troubleshooting charts for vane motors

<p>5. Unusual noise level</p>	<p>a) When the motor is running ?</p> <p>b) When the motor is braking ?</p>	<p>a-1) Check if there is no air intake that could aerate the fluid. a-2) Check if the motor is not cavitating. It could be that the inertia of the load is such that it drives the motor faster than the flow coming from the pump. a-3) Check if the fluid is suitable for the use. a-4) Check if the air bleed-off has been done properly.</p> <p>b-1) Check the back pressure to see if the replenishment pressure is not too low, leading to cavitation of the motor.</p>
<p>6. Unusual heat level</p>	<p>a) Is the fluid arriving to the motor already hot ?</p> <p>b) Is the fluid heating up when going through the motor ?</p>	<p>a-1) Check if a cooler is required or, if there is one, if it is well dimensioned. a-2) If there is a cooler, check if it is working (example for water cooler : is the water flow open or sufficient ?). a-3) Check if the hydraulic circuit is not bringing back the flow directly to the inlet port. Doing so, it would create a small closed circuit not able to cool down the fluid. a-4) Check the quality of the fluid. a-5) Check the velocity of the fluid (6 m/s max.). a-6) Check the filtration unit, its capacity. a-7) Check if the heat does not come from an open bypass valve.</p> <p>b-1) Check the speed of rotation versus the catalogue values. b-2) Check the pressure rating. b-3) Check the fluid type. b-4) Check the viscosity.</p>
<p>7. Shaft end leakage</p>	<p>a) Is it leaking when pressurized ?</p> <p>b) Is it leaking when standing still ?</p>	<p>a-1) Check that the shaft bearing is not damaged (dark grease leaking out of the ball bearing). a-2) Check that the drain line is not too much pressurized, which could have destroyed the shaft seal inside the motor (fluid leaking outside the shaft bearing race). a-3) Check that the environment, the fluid temperature and viscosity are appropriate (melted grease due to too high temperature or oil leakage due to a burned shaft seal). a-4) Check if there is no high overshoot at start-up that would create a high instant internal leakage. a-5) Check, when using a "quick coupling connector" for the drain line, that it is correctly locked. a-6) Check the alignment of the shafts.</p> <p>b-1) Check that the shaft bearing is not damaged (dark grease leaking out of the ball bearing). b-2) Check that the drain line is not too much pressurized, which could have destroyed the shaft seal inside the motor (fluid leaking outside the shaft bearing journal). b-3) Check that the environment, the fluid temperature and viscosity are appropriate (melted grease due to too high temperature or oil leakage due to a burned shaft seal).</p>

Notes

Notes

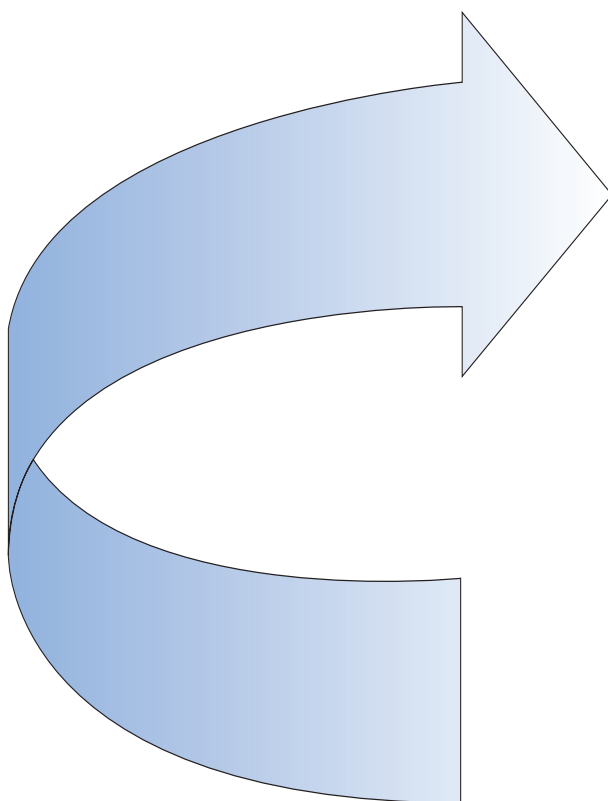

Component analysis table



WARNING – USER RESPONSIBILITY

FAILURE OR IMPROPER SELECTION OR IMPROPER USE OF THE PRODUCTS DESCRIBED HEREIN OR RELATED ITEMS CAN CAUSE DEATH, PERSONAL INJURY AND PROPERTY DAMAGE.

This document and other information from Parker-Hannifin Corporation, its subsidiaries and authorized distributors provide product or system options for further investigation by users having technical expertise.

The user, through its own analysis and testing, is solely responsible for making the final selection of the system and components and assuring that all performance, endurance, maintenance, safety and warning requirements of the application are met. The user must analyze all aspects of the application, follow applicable industry standards, and follow the information concerning the product in the current product catalog and in any other materials provided from Parker or its subsidiaries or authorized distributors.

To the extent that Parker or its subsidiaries or authorized distributors provide component or system options based upon data or specifications provided by the user, the user is responsible for determining that such data and specifications are suitable and sufficient for all applications and reasonably foreseeable uses of the components or systems.

Offer of Sale

Please contact your Parker representation for a detailed "Offer of Sale".

Component analysis table

6. COMPONENT ANALYSIS TABLE

	Pages	Bush Bearing	Cam ring	Pins	Rotor	Screw	Seal	Shaft	Port plate	Spring	Vane	
Pump	13							x				
	14							x				
	15							x				
	16		x	x				x	x			
	17							x	x			
	18						x			x		
	19									x		
	20			x		x						
	21									x		
	22			x							x	
	23					x			x			
	24			x		x				x		
	25								x			
	26									x		
	27		x	x						x	x	
	28					x				x		
	29											
	30			x						x		
	31			x	x	x				x	x	
	32					x			x			
	33					x						
	34			x		x					x	
	35					x				x		
	36									x		
	37			x		x					x	
	38			x		x						
	39					x				x		
	Motor	43		x		x			x			
		44				x				x		
45									x	x		
46			x						x			
47			x			x				x		



Parker Worldwide

Europe, Middle East, Africa

AE – United Arab Emirates,
Dubai

Tel: +971 4 8127100
parker.me@parker.com

AT – Austria, Wiener Neustadt
Tel: +43 (0)2622 23501-0
parker.austria@parker.com

AT – Eastern Europe, Wiener
Neustadt
Tel: +43 (0)2622 23501 900
parker.easteurope@parker.com

AZ – Azerbaijan, Baku
Tel: +994 12 47 73 799
parker.azerbaijan@parker.com

BE/LU – Belgium, Nivelles
Tel: +32 (0)67 280 900
parker.belgium@parker.com

BY – Belarus, Minsk
Tel: +375 17 209 9399
parker.belarus@parker.com

CH – Switzerland, Etoy
Tel: +41 (0)21 821 87 00
parker.switzerland@parker.com

CZ – Czech Republic, Klecany
Tel: +420 284 083 111
parker.czechrepublic@parker.com

DE – Germany, Kaarst
Tel: +49 (0)2131 4016 0
parker.germany@parker.com

DK – Denmark, Ballerup
Tel: +45 43 56 04 00
parker.denmark@parker.com

ES – Spain, Madrid
Tel: +34 902 330 001
parker.spain@parker.com

FI – Finland, Vantaa
Tel: +358 (0)20 753 2500
parker.finland@parker.com

FR – France, Contamine s/Arve
Tel: +33 (0)4 50 25 80 25
parker.france@parker.com

GR – Greece, Athens
Tel: +30 210 933 6450
parker.greece@parker.com

HU – Hungary, Budapest
Tel: +36 1 220 4155
parker.hungary@parker.com

IE – Ireland, Dublin
Tel: +353 (0)1 466 6370
parker.ireland@parker.com

IT – Italy, Corsico (MI)
Tel: +39 02 45 19 21
parker.italy@parker.com

KZ – Kazakhstan, Almaty
Tel: +7 7272 505 800
parker.easteurope@parker.com

NL – The Netherlands, Oldenzaal
Tel: +31 (0)541 585 000
parker.nl@parker.com

NO – Norway, Asker
Tel: +47 66 75 34 00
parker.norway@parker.com

PL – Poland, Warsaw
Tel: +48 (0)22 573 24 00
parker.poland@parker.com

PT – Portugal, Leca da Palmeira
Tel: +351 22 999 7360
parker.portugal@parker.com

RO – Romania, Bucharest
Tel: +40 21 252 1382
parker.romania@parker.com

RU – Russia, Moscow
Tel: +7 495 645-2156
parker.russia@parker.com

SE – Sweden, Spånga
Tel: +46 (0)8 59 79 50 00
parker.sweden@parker.com

SK – Slovakia, Banská Bystrica
Tel: +421 484 162 252
parker.slovakia@parker.com

SL – Slovenia, Novo Mesto
Tel: +386 7 337 6650
parker.slovenia@parker.com

TR – Turkey, Istanbul
Tel: +90 216 4997081
parker.turkey@parker.com

UA – Ukraine, Kiev
Tel: +380 44 494 2731
parker.ukraine@parker.com

UK – United Kingdom, Warwick
Tel: +44 (0)1926 317 878
parker.uk@parker.com

ZA – South Africa, Kempton Park
Tel: +27 (0)11 961 0700
parker.southafrica@parker.com

European Product Information Centre
Free phone: 00 800 27 27 5374

(from AT, BE, CH, CZ, DE, DK, EE, ES, FI,
FR, IE, IL, IS, IT, LU, MT, NL, NO, PL, PT,
RU, SE, SK, UK, ZA)

North America

CA – Canada, Milton, Ontario
Tel: +1 905 693 3000

US – USA, Cleveland
(industrial)
Tel: +1 216 896 3000

US – USA, Elk Grove Village
(mobile)
Tel: +1 847 258 6200

Asia Pacific

AU – Australia, Castle Hill
Tel: +61 (0)2-9634 7777

CN – China, Shanghai
Tel: +86 21 2899 5000

HK – Hong Kong
Tel: +852 2428 8008

IN – India, Mumbai
Tel: +91 22 6513 7081-85

JP – Japan, Fujisawa
Tel: +81 (0)4 6635 3050

KR – South Korea, Seoul
Tel: +82 2 559 0400

MY – Malaysia, Shah Alam
Tel: +60 3 7849 0800

NZ – New Zealand, Mt Wellington
Tel: +64 9 574 1744

SG – Singapore
Tel: +65 6887 6300

TH – Thailand, Bangkok
Tel: +662 717 8140

TW – Taiwan, Taipei
Tel: +886 2 2298 8987

South America

AR – Argentina, Buenos Aires
Tel: +54 3327 44 4129

BR – Brazil, Cachoeirinha RS
Tel: +55 51 3470 9144

CL – Chile, Santiago
Tel: +56 2 623 1216

MX – Mexico, Apodaca
Tel: +52 81 8156 6000

Ed. 2011-12-09

Parker Hannifin Limited

Tachbrook Park Drive
Tachbrook Park,
Warwick, CV34 6TU
United Kingdom
Tel.: +44 (0) 1926 317 878
Fax: +44 (0) 1926 317 855
parker.uk@parker.com
www.parker.com

